

Knitted Conductive EMI Gaskets



We practice environmental protection



Laird
TECHNOLOGIES®

Knitted Conductive EMI Gaskets

At Laird Technologies our commitment to providing design engineers with a variety of solutions for controlling electromagnetic leakage is evident in the knitted product line. Our range of knitted wire mesh and UltraSoft® knit products help prevent leakage along enclosure access doors and panels. Call us at the design stage and we'll work with your engineers to come up with the optimum solution for your specific application.

Our knitting machines are capable of processing various alloys from 0.0005 inch (0,013 mm) to 0.010 inch (0,254 mm) wire diameter for use as an EMI shield or vibration damper.



The Instron® Tester, a multiversed inspection tool, is used to check metal and gasket components for their properties and specifications.

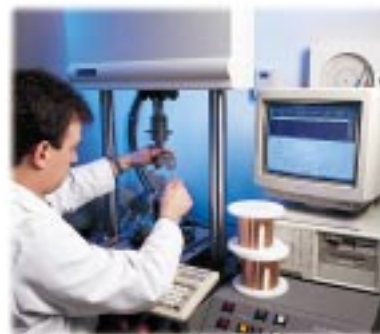

Quality is paramount at Laird Technologies. Equipment like this RAM-Optical machine is used to check for dimensional stability.









Our precision plating departments support and strictly comply with environmental, health and safety standards while offering a wide variety of plating finishes.



The EMI products presented in this section represent Laird Technologies' ongoing commitment to provide the design engineer with a complete range of solutions for controlling electromagnetic leakage along enclosure access doors and panels. To help the designer comply with susceptibility and

emission criteria for both commercial and military specifications, this section provides both design assistance and a comprehensive listing of products that best fit electrical, mechanical, and environmental EMI application requirements.

	Visual Part Reference Guide	4
	Part Number Cross Reference	5
	Introduction to Knitted Conductive EMI Gaskets	
	Ordering Information for Gaskets with PSA on Fin	6
	Mechanical Considerations	7
	Environmental Considerations	9
	UltraFlex® ElectroNit® Beryllium Copper Knitted Wire Shielding	10
	Hollow Core Round	
	Hollow Core Round with Single Fin	
	Hollow Core Double Round	
	D-shape with PSA	
	Fabricated UltraFlex® Gaskets	
	ElectroNit® All Mesh EMI Gasketing	13
	All Mesh Single Round with Fin Strip	
	All Mesh Double Round with Fin Strip	
	All Mesh Rectangular Strip	
	All Mesh Round Strip	
	Fabricated All Mesh Gaskets	
	ElectroNit® Elastomer Core EMI Gasketing	16
	Rectangular with Sponge Elastomer	
	Round with Sponge Elastomer	
	Round with Silicone Elastomer Tubing	
	Single Fin with Sponge Elastomer	
	Double Fin with Sponge Elastomer	
	Single Fin with Silicone Elastomer Tubing	
	Double Fin with Silicone Elastomer Tubing	
	Fabricated Elastomer Core Gaskets	
	ElectroNit® Enviro-Seal™ EMI Gasketing	19
	Enviro-Seal™ Strips with PSA	
	Enviro-Seal™ Double Shield Strips with PSA	
	Fabricated Enviro-Seal™ Gaskets	

	ElectroNit® Flat Band	21
	UltraSoft® Knit Gaskets	22
	ElectroNit® SuperSoft	24
	Electro-Ground EMI Washers	25
	Channel Clip-On Gaskets	28
	Corrosion of EMI Gaskets	29
	Metals Galvanic Compatibility Chart	30

Instron® is a registered trademark of Instron Corporation. Monel® is a registered trademark of Inco Alloys International, Inc. ElectroGround™, ElectroMesh™, ElectroNit®, Enviro-Seal™, UltraFlex® and UltraSoft® are trademarks of Laird Technologies.

Notice:
Information on the products described in this catalog is based on laboratory test data which Laird Technologies believes to be reliable. However, Laird Technologies has no control over the design of actual products which incorporate Laird Technologies' products or actual fabrication of devices using Laird Technologies' products. Accordingly, Laird Technologies cannot guarantee that the same test data as described herein will be obtained. Thus, it is recommended that each user make their own tests to confirm laboratory test data and determine suitability of Laird Technologies' products for their particular application.

The products described in this catalog shall be standard quality, however, the products in this catalog are sold without warranty of fitness for a particular purpose, either expressed or implied, except to the extent expressly stated on Laird Technologies' invoice, quotation or order acknowledgment. Laird Technologies does not warrant that devices incorporating one or more of the products described in this catalog will be free of conflict with existing or future patents of third parties. All risks of lack of fitness, patent infringement, and the like are assumed by the user. Furthermore, nothing contained herein shall be construed as a recommendation to make, use, or sell any product or process in conflict with existing or future patents.

We reserve the right to change technical specifications without notice and take no responsibility for errors and misprints.

Tolerances on inquiry.





Knitted Conductive EMI Gaskets

UltraFlex® ElectroNit® BeCu Knitted Wire Shielding

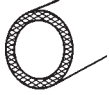

Hollow Core Round

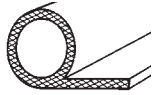

Hollow Core Round with Single Fin



Hollow Core Double Round

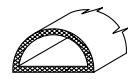

D-shape with PSA

Page 10 - 12

ElectroNit® All Mesh EMI Gasketing

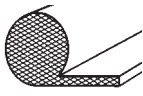

All Mesh Single Round with Fin Strip

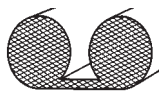

All Mesh Double Round with Fin Strip

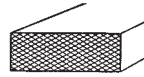

All Mesh Rectangular Strip



All Mesh Round Strip

Page 13 - 15

ElectroNit® Elastomer Core EMI Gasketing

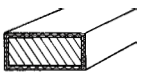

Rectangular with Sponge Elastomer



Round with Sponge Elastomer



Round with Silicone Elastomer Tubing



Single Fin with Sponge Elastomer



Single Fin with Silicone Elastomer Tubing

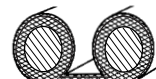

Double Fin with Sponge Elastomer



Double Fin with Silicone Elastomer Tubing

Page 16 - 18

ElectroNit® Enviro-Seal™ EMI Gaskets



Enviro-Seal™ Strip with Pressure-Sensitive Adhesive (PSA)



Double Shield Enviro-Seal™ Strip with Pressure-Sensitive Adhesive (PSA)

Page 19 - 20

ElectroNit® Flat Band



Page 21

UltraSoft® Knit Gaskets

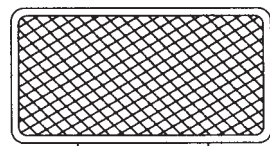

Page 22 - 23

ElectroNit® SuperSoft



Page 24

ElectroGround™ EMI Washers

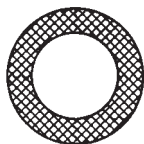

Page 25 - 27

Channel Clip-On

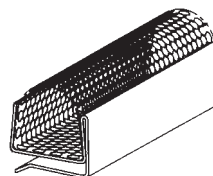

Page 28



When ordering, please call our sales department to confirm availability and lead times.

Knitted Conductive EMI Gaskets

Part No.	Product	Page No.
ULTRAFLEX® ELECTRONIT® BECU KNITTED WIRE SHIELDING		
8101-01XX-40,41,47,48,49	HOLLOW CORE ROUND	Page 11
8102-02XX-40,41,47,48,49	D-SHAPE WITH PSA	Page 11
8103-01XX-40,41,47,48,49	HOLLOW CORE ROUND WITH SINGLE FIN	Page 11
8104-01XX-40,41,47,48,49	HOLLOW CORE DOUBLE ROUND	Page 11
ELECTRONIT® ALL MESH EMI GASKETING		
70XX-01XX	ALL MESH ROUND STRIP	Page 14
70XX-02XX	ALL MESH RECTANGULAR STRIP	Page 14
70XX-03XX	ALL MESH DOUBLE ROUND WITH FIN STRIP	Page 14
70XX-04XX	ALL MESH SINGLE ROUND WITH FIN STRIP	Page 14
70XX-05XX	ELECTRONIT® FLAT BAND	Page 21
ELECTRONIT® ENVIRO-SEAL™ EMI GASKETS		
40XX-10XX	ELECTRONIT® ENVIRO-SEAL™ STRIPS WITH PSA	Page 20
ELECTRONIT® ELASTOMER CORE EMI GASKETING		
8XXX-22XX	RECTANGULAR WITH SPONGE ELASTOMER	Page 17
8XXX-23XX	SINGLE FIN WITH SPONGE ELASTOMER	Page 17
8XXX-20XX	ROUND WITH SPONGE ELASTOMER	Page 17
8XXX-24XX	DOUBLE FIN WITH SPONGE ELASTOMER	Page 18
8XXX-21XX	ROUND WITH SILICONE ELASTOMER TUBING	Page 17
8XXX-22XX	ELECTRONIT® SUPERSOFT	Page 24
8417-3XXX-62	ULTRASOFT® KNIT GASKETS	Page 23
CHANNEL CLIP-ON		
8644-0100-41,65	CHANNEL CLIP-ON GASKETS (FOUR-PIECE GASKET)	Page 28
8645-0100-41,65	CHANNEL CLIP-ON GASKETS (ONE-PIECE GASKET)	Page 28
89XX-01XX-40,42,43,44,46	ELECTROGROUND™ EMI WASHERS	Page 26, 27



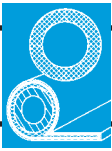

Knitted Conductive EMI Gaskets

EMI gasketing that best fits shielding requirements is determined by the environmental and mechanical considerations of the equipment to be shielded. This design guide is intended to aid the engineer in determining the product that will provide the optimum shielding effectiveness or grounding within mechanical constraints including metal thickness, material type, plating, bolt spacing, and interface dimensions.

The products shown are supplied on a spool by the meter, and can be installed by the customer by simply cutting to the desired length during assembly. It is recommended that a Laird Technologies engineer be contacted early in the design stage. The engineer can assist in designing a unit gasket assembly and can help determine whether it would be beneficial for gasketing to be provided in either frame form or cut to a specific length. On large production quantities, these techniques have proven to be very cost-effective, as the gasket is received as a finished item ready for installation.

Location of pressure-sensitive adhesive (PSA) on Fin

Figure 1.

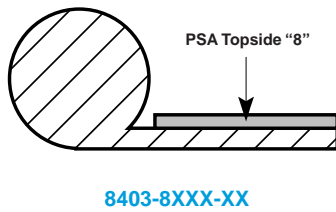

8403-8XXX-XX

Figure 2.

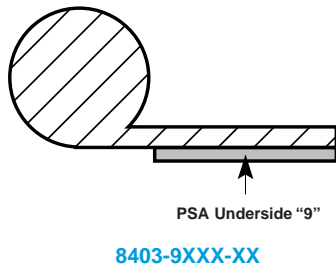

8403-9XXX-XX

Figures 3a through 3e illustrate several widely used techniques for mounting:

Figure 3a.

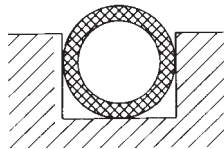

Groove Mounting
In groove mounting, gasket should have sufficient clearance to achieve optimum contact when compressed to desired tolerance.

Figure 3b.

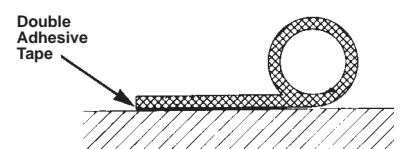

Adhesive Mounting
Adhesive strip is applied only beneath the fin area, allowing the conductive knitted mesh direct contact with the host material.

Figure 3c.

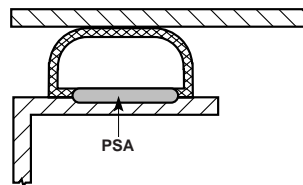

Partition with Flat Contact

Figure 3d.

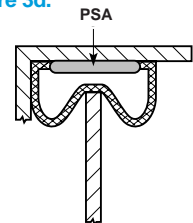

Partition with Knife-Edge Contact

Figure 3e.

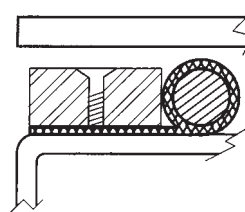

Elastomer Core with Hold Down Bar and Positive Stop

All dimensions shown are in inches (millimeters) unless otherwise specified.



Mechanical Considerations

Gasket Interface Design

The optimum condition for an EMI gasket mounting is a rigid machined flat surface with bolts located outside the gasket contact area. This condition, however, is not practical or possible in most shielding applications. Therefore the choice of an EMI gasket that meets the required shielding effectiveness, and at the same time will be adapted to interface constraints of the enclosure package, are major considerations in designing an effective EMI gasket.

Flat Flange Mounting

The most common method of grounding between two mating surfaces is with a flat gasket mounted between surfaces as shown in Figure 4. This method is particularly effective in joints where there is an occasional need to open the enclosure for maintenance purposes. It is recommended that a positive stop be used to prevent overcompression of the gasket which could reduce effectiveness when the lid is secured after opening.

All gasket materials have an elastic limit and are subject to taking a set if over-compressed. Figures 5a and 5b show methods for incorporating a stop into the gasket enclosure design. It is recommended that stops be designed to the maximum suggested compression limits of the gasket material used.

Figure 4. Flat Gasket between Sheet Metal Flange

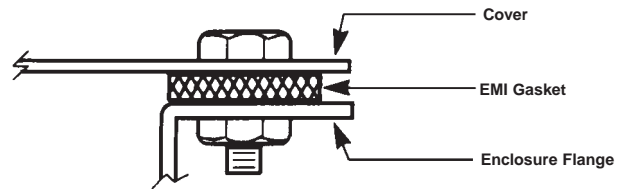

Figure 5a. Cover with Compression Stop

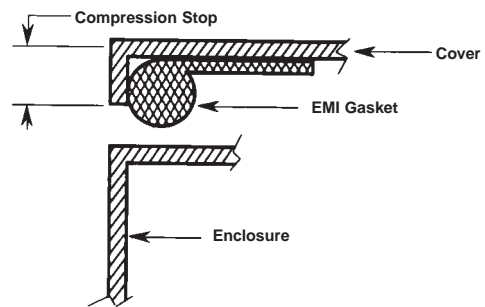
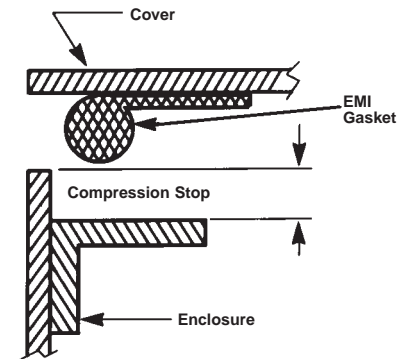
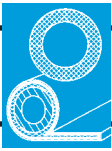

Figure 5b. Compression Stop Built into Enclosure





EMI Gasket Mating Surfaces

During initial enclosure-gasket interface design, it is important that the impedance between the mating surfaces be as nearly equal to that of the enclosure material as possible. Any significant difference in surface impedance through the gasket material can produce fluctuations in current flow, resulting in the generation of EMI voltages. These fluctuating voltages can create the leakage of radiated energy into or from the enclosure. Features to consider in the gasket interface design are as follows:

1. Gasketed surfaces should be protected with a conductive coating such as tin, nickel, or zinc.
2. Mating surfaces should be as flat as possible considering the manufacturing method, i.e., bending or machining.
3. Mating surfaces should be cleaned of oxides prior to assembly of the gasketing material.

The mechanical aspects of EMI gasket interface design are an important factor in ensuring a reliable EMI shield. Joint unevenness, or the degree of mismatch of mating surfaces, is one of the most important design considerations. This match results when the mating surfaces make contact at irregular intervals due to surface roughness or bowing of the gasket interface due to improper material selection or thickness of the mating plates. Excessive bolt tightening, too few fasteners, or improper gasket selection can also affect gasket bowing. An effective EMI gasket should make continuous and uniform contact with the mating surfaces. The shielding performance of a gasketed enclosure can be adversely affected by improper mating of the gasketed interface due to joint unevenness.

To emphasize the effect of a gasketed joint, Figure 6a shows a seam without gasket material joining and touching only at the regular high spots between the surfaces. It is the function of an EMI gasket to bridge the gaps between these irregularities without losing the properties of resiliency or conductivity. The maximum joint unevenness is the dimension of the maximum separation between the flange of the seam when the two surfaces are touching. This separation is designated as ΔH , as shown in Figure 6a. With a gasket in place, the maximum spacing (H_1) between mating surfaces occurs at the minimum gasket compression. Conversely, the minimum spacing (H_2) occurs at the maximum gasket compression as shown in Figure 6b. The difference between the maximum (H_1) and the minimum (H_2) spacing is ΔH . Under these extreme conditions, the gasket undergoes its severest mechanical tests at the maximum deflection and severest electrical tests at the minimum deflection.

Figure 6a. Uneven Joint without Gasket

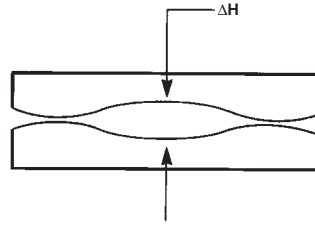
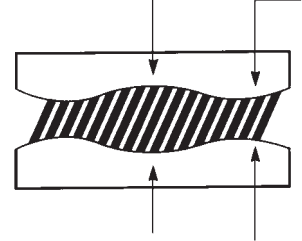

Figure 6b. Uneven Joint with Gasket



With joint unevenness such a critical factor, it is important to consider the following when designing an EMI gasket or specific interface:

1. Gasket deflection
2. Compression set
3. Shielding effectiveness
4. Environmental sealing needs

These considerations can be related to the three classifications of joints, defined as follows:

Class 1 – Permanently mounted cover plates or assemblies. Generally, compression set is not a concern in these applications, even though high pressures may be encountered.

Class 2 – Access cover plate with high joint unevenness, which is opened frequently, but always closes on the same portion of the gasket. A hinged door is an example of a Class 2 joint.

Class 3 – A removable access plate, with symmetrically mounted fasteners, that is replaceable but not necessarily in the original orientation. Gaskets for this type of application are removable and reusable. Gasket materials which exhibit low closure force and low compression set are to be considered for this application.

Closure Force

Figure 7 on page 9 shows the relationship between shielding effectiveness and closure force. The minimum force (P_{MIN}) is the recommended applied force to establish good shielding effectiveness and to minimize the effect of minor pressure differences. The maximum recommended closure force (P_{MAX}) is based on two criteria: 1) maximum compression set of 10%; 2) avoidance of possible damage to the gasket material when pressure exceeds the recommended maximum. Both gasket materials have optimum performance at 25% to 30% deflection. Using the deflection versus pressure curves in the product descriptions of this catalog can determine the optimum pressure for the 25% deflection.

All dimensions shown are in inches (millimeters) unless otherwise specified.



Figure 7. Shielding Effectiveness vs. Compression Force

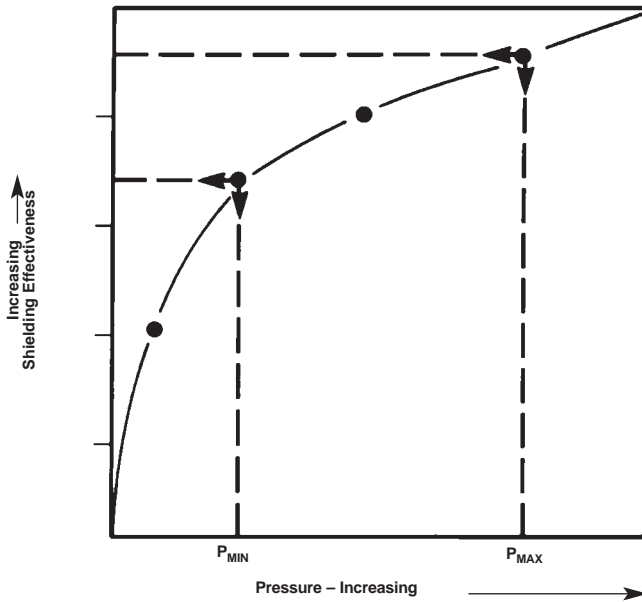

Compression Set

As previously mentioned, use of compression stops built into an enclosure or supplied with the EMI gasket aids in controlling the amount of deflection, thus minimizing the amount of compression set. Selection of a gasketing material for a joint which must be opened and closed is, to a large extent, determined by the compression set characteristics of the gasket material. Most resilient gasket materials will recover most of their original height after being deflected no greater than 25%-30%. The difference between the original height and the height after the compression force is removed, is the compression set. Compression set increases as the deflection pressure is increased.

Environmental Considerations

The choice of gasket materials and surface finish of an enclosure is a function of the operating or storage temperature of the electronic package. Most electronic packages, however, must be designed for one of the following five general environments:

Class A – Controlled Environment – Temperature and humidity are controlled, generally indoor applications.

Class B – Uncontrolled Environment – Temperature and humidity are not controlled, exposed to humidities at 100% with occasional wetting, outdoor exposure or exposure in uncontrolled warehouses.

Class C – Marine Environment – Shipboard exposure or land exposure within two miles of salt water where conditions of Class A are not met.

Class D – Space Environment – Exposure to high vacuum and high radiation.

Class E – Nuclear, Biological, Chemical (NBC) – Applications subject to exposure to solvents used to break down NBC toxic substances.

Choice of an elastomer used in a knitted wire product for a resilient core is a function of the class in which the specific equipment will be operated or stored. The elastomer materials listed below are commonly used in conjunction with EMI gasketing materials, as bonded constructions such as the Enviro-Seal™ product, or the elastomer core products, defined in this catalog.

Neoprene

This elastomer is commonly used in conjunction with EMI gaskets in the Class A environment and will withstand temperatures ranging from -65°F to 212°F (-54°C to 100°C) for the solid material and -25°F to 212°F (-32°C to 100°C) for the closed cell sponge elastomer. The neoprene materials are the least expensive of the synthetic rubber materials and are best suited for commercial applications from a cost standpoint.

Silicone

This material has outstanding physical characteristics and will operate continuously at temperatures ranging from -80°F to 500°F (-62°C to 260°C) for solid and -103°F to 401°F (-75°C to 205°C) for closed cell sponge silicone. These materials remain flexible and are highly resistant to water and swelling in the presence of hydrocarbons.

Note:

For materials compatibility in a corrosive environment, see the Metals Galvanic Compatibility Chart on the inside back cover.

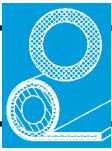

UltraFlex® ElectroNit® Beryllium Copper Knitted Wire Shielding

UltraFlex® ElectroNit® combines the optimum mechanical properties of beryllium copper with shielding effectiveness as much as 20 dB higher than conventional materials. It offers superb resiliency for consistent, point-to-point contact requiring the lowest compression forces among all other shielding materials and configurations. A wide range of platings, sizes, configurations, and excellent flexibility create optimum design latitude.

- Compression force 80% less than conventional knitted wire shielding with elastomer core
- >90% recovery of original height at up to 75% deflection preserving original shielding effectiveness values
- Optimum attenuating properties of beryllium copper, one of shielding's most effective materials
- Up to 75% lighter than conventional wire knit materials
- High cycle life for high traffic applications
- No moisture absorption
- Available in UltraFlex® Lite single strand BeCu mesh, offering 50% load reduction from standard product
- Also offered in aluminum and stainless steel for increased galvanic compatibility with mating surfaces
- Other platings available upon request

UltraFlex® is supplied on spools in continuous minimum lengths of 25 ft. (7,6 m).



Patent No. 5,294,270

Hollow core UltraFlex® is available in round, round with single fin, double round configuration, and D shape.

Compression-Deflection

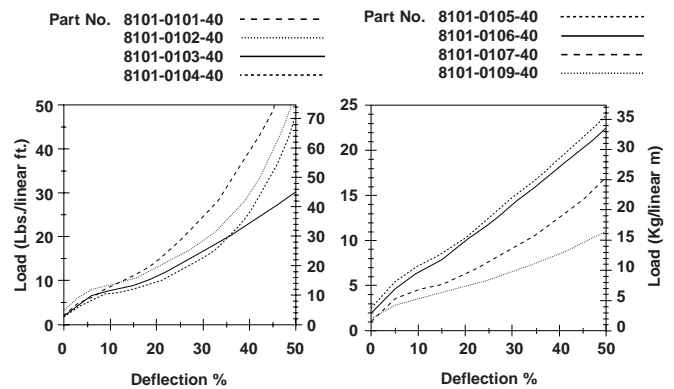

Shielding Effectiveness

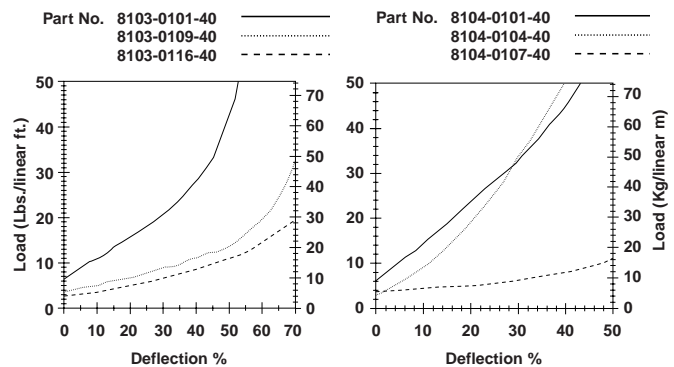
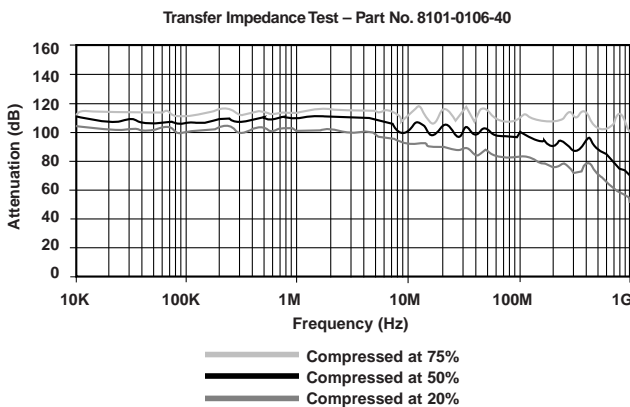

All dimensions shown are in inches (millimeters) unless otherwise specified.

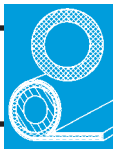

UltraFlex® ElectroNit® Beryllium Copper Knitted Wire Shielding

Size vs. Tolerance: UltraFlex® Hollow Core Round

Size Range	Tolerance	
	Diameter	
To 0.120 (3,1)	+ 0.020/- 0.000 (+0,5/-0,0)	
0.130 to 0.380 (3,3 to 9,7)	+ 0.030/- 0.000 (+0,8/-0,0)	
0.390 to 0.050 (9,9 to 12,7)	+ 0.046/- 0.000 (+1,2/-0,0)	
0.510 to 1.000 (13,0 to 25,4)	+ 0.062/- 0.000 (+1,6/-0,0)	

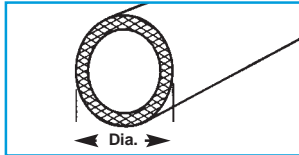

Groove Dimensions

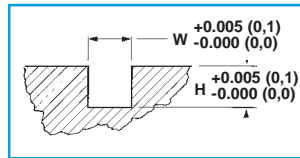

UltraFlex® Hollow Core Round

Part No.	Groove Dimensions		Diameter
	W	H	
8101-0101-40	0.060 (1,5)	0.047 (1,2)	0.062 (1,6)
8101-0102-40	0.090 (2,3)	0.069 (1,8)	0.093 (2,4)
8101-0103-40	0.120 (3,1)	0.093 (2,4)	0.125 (3,2)
8101-0104-40	0.150 (3,8)	0.117 (3,0)	0.156 (4,0)
8101-0105-40	0.180 (4,6)	0.140 (3,6)	0.187 (4,8)
8101-0106-40	0.240 (6,1)	0.187 (4,8)	0.250 (6,4)
8101-0107-40	0.292 (7,4)	0.234 (5,9)	0.312 (7,9)
8101-0108-40	0.360 (9,1)	0.281 (7,1)	0.375 (9,5)
8101-0109-40	0.485 (12,3)	0.375 (9,5)	0.500 (12,7)
8101-0135-40	0.730 (18,5)	0.563 (14,3)	0.750 (19,1)

Size vs. Tolerance: UltraFlex® Hollow Core Round with Single Fin

Size Range	Tolerance	
	Dim W	Dim H
To 0.180 (4,6)	N/A	+ 0.020/- 0.000 (+0,5/-0,0)
0.190 to 0.380 (4,8 to 9,7)	+ 0.060/- 0.030 (+1,5/-0,8)	+ 0.030/- 0.000 (+0,8/-0,0)
0.390 to 0.050 (9,9 to 12,7)	+ 0.060/- 0.060 (+1,5/-1,5)	+ 0.046/- 0.000 (+1,2/-0,0)
0.510 to 1.000 (13,0 to 25,4)	+ 0.090/- 0.060 (+2,3/-1,5)	+ 0.062/- 0.000 (+1,6/-0,0)

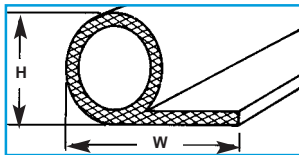

UltraFlex® Hollow Core Round with Single Fin

Part No.	Width	Height
8103-0125-40	0.300 (7,6)	0.093 (2,4)
8103-0101-40	0.375 (9,5)	0.062 (1,6)
8103-0104-40	0.375 (9,5)	0.125 (3,2)
8103-0118-40	0.375 (9,5)	0.156 (4,0)
8103-0102-40	0.500 (12,7)	0.062 (1,6)
8103-0103-40	0.500 (12,7)	0.093 (2,4)
8103-0107-40	0.500 (12,7)	0.156 (4,0)
8103-0109-40	0.500 (12,7)	0.250 (6,4)
8103-0117-40	0.500 (12,7)	0.375 (9,5)
8103-0105-40	0.625 (15,9)	0.125 (3,2)
8103-0108-40	0.625 (15,9)	0.187 (4,8)
8103-0112-40	0.625 (15,9)	0.312 (7,9)
8103-0106-40	0.750 (19,1)	0.125 (3,2)
8103-0110-40	0.750 (19,1)	0.250 (6,4)
8103-0113-40	0.875 (22,2)	0.312 (7,9)
8103-0111-40	1.000 (25,4)	0.250 (6,4)
8103-0114-40	1.000 (25,4)	0.375 (9,5)
8103-0115-40	1.000 (25,4)	0.437 (11,1)
8103-0116-40	1.000 (25,4)	0.500 (12,7)

Size vs. Tolerance: UltraFlex® Hollow Core Double Round

Size Range	Tolerance	
	Dim W	Dim H
To 0.180 (4,6)	N/A	+ 0.020/- 0.000 (+0,5/-0,0)
0.190 to 0.380 (4,8 to 9,7)	+ 0.060/- 0.030 (+1,5/-0,8)	+ 0.030/- 0.000 (+0,8/-0,0)
0.390 to 0.050 (9,9 to 12,7)	+ 0.060/- 0.060 (+1,5/-1,5)	+ 0.046/- 0.000 (+1,2/-0,0)
0.510 to 1.000 (13,0 to 25,4)	+ 0.090/- 0.060 (+2,3/-1,5)	+ 0.062/- 0.000 (+1,6/-0,0)

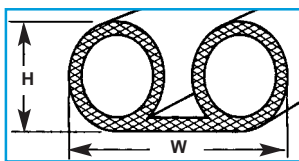

UltraFlex® Hollow Core Double Round

Part No.	Width	Height
8104-0101-40	0.500 (12,7)	0.062 (1,6)
8104-0102-40	0.500 (12,7)	0.125 (3,2)
8104-0105-40	0.625 (15,9)	0.187 (4,8)
8104-0103-40	0.750 (19,1)	0.125 (3,2)
8104-0107-40	0.750 (19,1)	0.250 (6,4)
8104-0104-40	1.000 (25,4)	0.125 (3,2)
8104-0106-40	1.000 (25,4)	0.187 (4,8)
8104-0108-40	1.000 (25,4)	0.250 (6,4)
8104-0109-40	1.000 (25,4)	0.375 (9,5)

Size vs. Tolerance: D-shape with PSA

Size Range	Tolerance	
	Dim W	Dim H
0.120 to 0.250 (3,1 to 6,4)	+ 0.030/- 0.000 (+0,8/-0,0)	+ 0.030/- 0.000 (+0,8/-0,0)
0.260 to 0.380 (6,6 to 9,7)	+ 0.040/- 0.000 (+1,0/-0,0)	+ 0.040/- 0.000 (+1,0/-0,0)
0.390 to 0.050 (9,9 to 12,7)	+ 0.050/- 0.000 (+1,3/-0,0)	+ 0.040/- 0.000 (+1,0/-0,0)

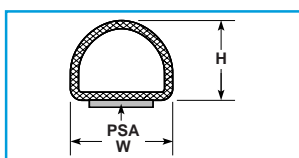

For Size vs. Tolerance charts, dimensions measured under 4 oz. load (11,3 gms) with 0.750 dia. (19,1 mm) anvil.

D-shape with PSA

Part No.	Width	Height
8102-0202-40	0.200 (5,1)	0.130 (3,3)
8102-0209-40	0.250 (6,4)	0.125 (3,2)
8102-0203-40	0.250 (6,4)	0.190 (4,8)
8102-0204-40	0.312 (7,9)	0.250 (6,4)
8102-0205-40	0.380 (9,7)	0.312 (7,9)
8102-0206-40	0.500 (12,7)	0.375 (9,5)
8102-0207-40	0.750 (19,1)	0.670 (17,0)

For other platings, replace the suffix "40" as follows: **41**-Tin plate; **47**-Nickel plate; **48**-Cadmium plate; **49**-Zinc clear chromate. Other platings available upon request.

All dimensions shown are in inches (millimeters) unless otherwise specified.



Compression Recovery

An important feature of UltraFlex® shielding gaskets is their capability to recover 90% or more of their free height after repeated deflections of up to 75% of free height.

Table 1 indicates cycle recovery data for standard UltraFlex® diameters.

Table 1. UltraFlex® Compression Cycle Test Recovery Data

Part No.	% of Deflection	Recovery % After Cycle		
		100 Cycles	250 Cycles	500 Cycles
8101-0101-40	25	100	98	98
	50	98	98	94
	75	98	98	94
8101-0102-40	25	100	100	100
	50	98	98	96
	75	92	90	88
8101-0103-40	25	96	96	96
	50	96	96	96
	75	96	95	95
8101-0104-40	25	98	98	98
	50	98	98	98
	75	89	88	88
8101-0105-40	25	100	100	100
	50	100	98	98
	75	97	96	96
8101-0106-40	25	100	100	100
	50	100	100	99
	75	100	100	98
8101-0107-40	25	98	98	98
	50	98	98	97
	75	95	95	95
8101-0108-40	25	100	100	100
	50	100	99	99
	75	100	100	98
8101-0109-40	25	100	100	100
	50	98	98	97
	75	98	98	97

Fabricated UltraFlex® Gaskets

The UltraFlex® products featured in this section can be supplied in bulk form on spools, or as individual gaskets fabricated to user specifications.

Shown below are diagrams of conventional O-ring and cut-to-length constructions.

Figure 1. O-Ring Construction

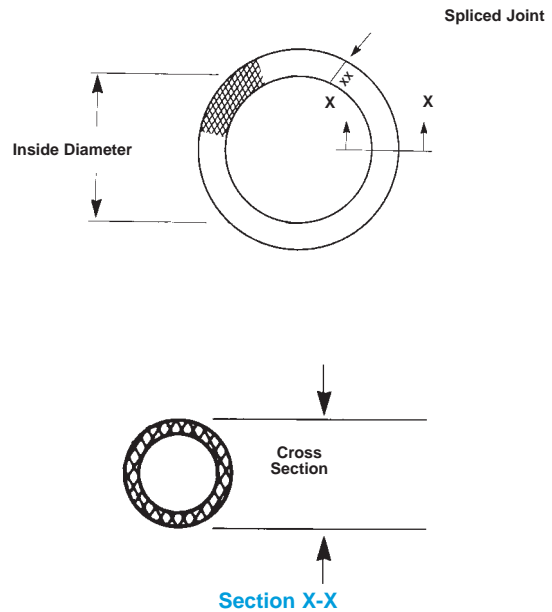
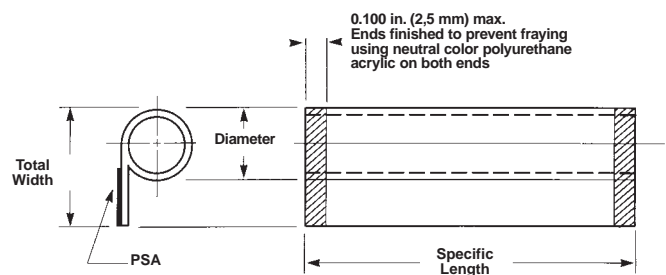

Figure 2. Cut-to-length Construction Hollow Core with Fin and PSA Tape



All dimensions shown are in inches (millimeters) unless otherwise specified.



ElectroNit® All Mesh EMI Gasketing

Laird Technologies ElectroNit® All Mesh EMI Gasketing has been designed to offer the highest possible levels of attenuation. Knit construction enhances long lasting resiliency, making it an ideal material for highly sensitive components in permanent or semi-permanent enclosures where environmental sealing is not a concern.

- Highest attenuation characteristics
- Monel®, tin plated copper clad steel, aluminum and stainless steel
- Versatile mounting
- Consistent point-to-point contact for high shielding effectiveness over life of gasket

ElectroNit® All Mesh EMI Gasketing is supplied on spools. It is available in various alloys.

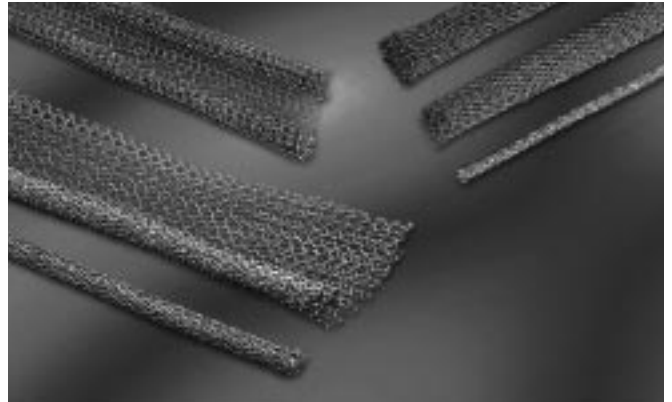

ElectroNit® All Mesh Gasketing is available in a wide range of sizes in round or rectangular cross sections, as well as round with fin, and double round configurations.

Table 1. Material Specifications

Material Code	Wire Type	Specification
7011-	Monel®	Ø 0.004 inch (Ø 0,114 mm) as per DIN 17743/17750, Material-no. 2.4360
7012-	Aluminium	Ø 0.005 inch (Ø 0,127 mm) as per DIN 1725, Material-no. 3.3555, AMS-4182, Alloy 5056
7013-	Stainless steel	Ø 0.004 inch (Ø 0,114 mm) as per DIN 17440, Material-no. 1.4301 (9 % Ni, 18 % Cr, 73 % Fe)
7014-	SCF	Ø 0.004 inch (Ø 0,114 mm), ASTM-B-520

Shielding Performance

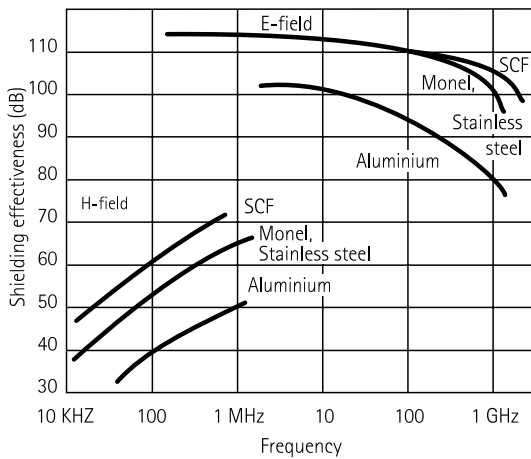

Compression Force

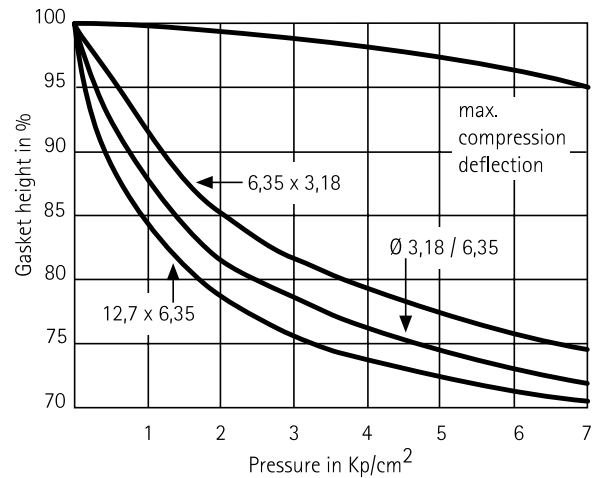

Mechanical Tolerances

0.059 - 0.197 inch:	+ 0.016 - 0 inch
1,5 - 5 mm:	+ 0,4 - 0 mm
>0.197 - 0.394 inch:	+ 0.024 - 0 inch
5,0 - 10 mm:	+ 0,6 - 0 mm
> 0.394 - 0.669 inch:	+ 0.031 - 0 inch
>10,0 - 17 mm:	+ 0,8 - 0 mm

All dimensions shown are in inches (millimeters) unless otherwise specified.

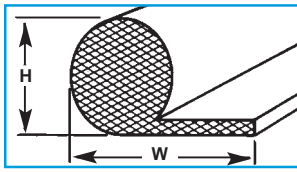
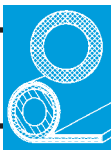

All Mesh Single Round with Fin Strip

Part No.	Round Portion Height	Width	Part No.	Round Portion Height	Width	Part No.	Round Portion Height	Width
-0401	0.063 (1,6)	0.531 (13,5)	-0416	0.189 (4,8)	0.531 (13,5)	-0427	0.311 (7,9)	0.874 (22,2)
-0402	0.063 (1,6)	0.626 (15,9)	-0417	0.189 (4,8)	0.626 (15,9)	-0428	0.374 (9,5)	0.626 (15,9)
-0403	0.063 (1,6)	0.752 (19,1)	-0418	0.189 (4,8)	0.752 (19,1)	-0429	0.374 (9,5)	0.752 (19,1)
-0405	0.095 (2,4)	0.531 (13,5)	-0419	0.189 (4,8)	0.874 (22,2)	-0430	0.374 (9,5)	0.874 (22,2)
-0406	0.095 (2,4)	(19,1) 0.752	-0420	0.252 (6,4)	0.531 (13,5)	-0431	0.374 (9,5)	1.000 (25,4)
-0409	0.126 (3,2)	0.531 (13,5)	-0421	0.252 (6,4)	0.626 (15,9)	-0432	0.437 (11,1)	0.752 (19,1)
-0410	0.126 (3,2)	0.563 (14,3)	-0422	0.252 (6,4)	0.752 (19,1)	-0433	0.437 (11,1)	0.874 (22,2)
-0411	0.126 (3,2)	0.626 (15,9)	-0423	0.252 (6,4)	0.874 (22,2)	-0434	0.437 (11,1)	1.000 (25,4)
-0412	0.126 (3,2)	0.752 (19,1)	-0424	0.252 (6,4)	1.000 (25,4)	-0435	0.500 (12,7)	0.752 (19,1)
-0413	0.158 (4,0)	0.531 (13,5)	-0425	0.311 (7,9)	0.626 (15,9)	-0436	0.500 (12,7)	0.874 (22,2)
-0414	0.158 (4,0)	0.752 (19,1)	-0426	0.311 (7,9)	0.752 (19,1)	-0437	0.500 (12,7)	1.000 (25,4)

other dimensions on request

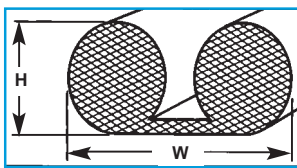

All Mesh Double Round with Fin Strip

Part No.	Round Height	Connecting Width	Part No.	Round Height	Connecting Width
-0301	0.063 (1,6)	0.531 (13,5)	-0329	0.157 (4,0)	0.709 (18,0)
-0302	0.063 (1,6)	0.626 (15,9)	-0311	0.189 (4,8)	0.626 (15,9)
-0303	0.063 (1,6)	0.752 (19,1)	-0312	0.189 (4,8)	0.752 (19,1)
-0304	0.063 (1,6)	0.874 (22,2)	-0313	0.189 (4,8)	0.874 (22,2)
-0323	0.079 (2,0)	0.984 (25,0)	-0314	0.189 (4,8)	1.000 (25,4)
-0305	0.094 (2,4)	0.531 (13,5)	-0315	0.252 (6,4)	0.752 (19,1)
-0306	0.126 (3,2)	0.531 (13,5)	-0316	0.252 (6,4)	0.874 (22,2)
-0307	0.126 (3,2)	0.626 (15,9)	-0317	0.252 (6,4)	1.000 (25,4)
-0308	0.126 (3,2)	0.752 (19,1)	-0318	0.374 (9,5)	1.000 (25,4)
-0309	0.126 (3,2)	0.874 (22,2)	-0319	0.374 (9,5)	1.252 (31,8)
-0310	0.126 (3,2)	1.000 (25,4)			

other dimensions on request

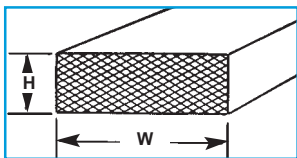

All Mesh Rectangular Strip

Part No.	Height H	Width W	Part No.	Height H	Width W	Part No.	Height H	Width W
-0200	0.063 (1,6)	0.063 (1,6)	-0215	0.095 (2,49)	0.374 (9,5)	-0230	0.189 (4,8)	0.311 (7,9)
-0201	0.063 (1,6)	0.126 (3,2)	-0216	0.095 (2,49)	0.500 (12,7)	-0231	0.189 (4,8)	0.374 (9,5)
-0202	0.063 (1,6)	0.189 (4,8)	-0217	0.095 (2,49)	0.626 (15,9)	-0232	0.189 (4,8)	0.500 (12,7)
-0203	0.063 (1,6)	0.252 (6,4)	-0218	0.126 (3,2)	0.126 (3,2)	-0233	0.189 (4,8)	0.626 (15,9)
-0204	0.063 (1,6)	0.311 (7,9)	-0219	0.126 (3,2)	0.157 (4,0)	-0234	0.189 (4,8)	0.752 (19,1)
-0205	0.063 (1,6)	0.374 (9,5)	-0220	0.126 (3,2)	0.189 (4,8)	-0235	0.189 (4,8)	1.000 (25,4)
-0206	0.063 (1,6)	0.500 (12,7)	-0221	0.126 (3,2)	0.252 (6,4)	-0236	0.252 (6,4)	0.252 (6,4)
-0207	0.063 (1,6)	0.626 (15,9)	-0222	0.126 (3,2)	0.311 (7,9)	-0237	0.252 (6,4)	0.311 (7,9)
-0208	0.063 (1,6)	0.752 (19,1)	-0223	0.126 (3,2)	0.374 (9,5)	-0238	0.252 (6,4)	0.374 (9,5)
-0209	0.063 (1,6)	0.961 (24,4)	-0224	0.126 (3,2)	0.500 (12,7)	-0239	0.252 (6,4)	0.500 (12,7)
-0210	0.095 (2,49)	0.094 (2,4)	-0225	0.126 (3,2)	0.626 (15,9)	-0240	0.252 (6,4)	0.626 (15,9)
-0211	0.095 (2,49)	0.126 (3,2)	-0226	0.126 (3,2)	0.752 (19,1)	-0241	0.252 (6,4)	0.752 (19,1)
-0212	0.095 (2,49)	0.189 (4,8)	-0227	0.126 (3,2)	1.000 (25,4)	-0243	0.311 (7,9)	0.311 (7,9)
-0213	0.095 (2,49)	0.252 (6,4)	-0228	0.189 (4,8)	0.189 (4,8)	-0244	0.374 (9,5)	0.374 (9,5)
-0214	0.095 (2,49)	0.311 (7,9)	-0229	0.189 (4,8)	0.252 (6,4)			

other dimensions on request

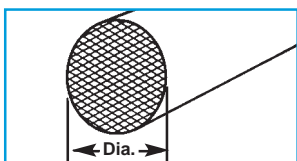

All Mesh Round Strip

Part No.	Diameter
-0100	0.063 (1,6)
-0101	0.094 (2,4)
-0102	0.126 (3,2)
-0103	0.157 (4,0)
-0104	0.189 (4,8)
-0105	0.252 (6,4)
-0106	0.311 (7,9)
-0107	0.374 (9,5)
-0108	0.437 (11,1)
-0109	0.500 (12,7)

other dimensions on request

Ordering Information

The ordering code consists of the material code, followed by the part no.:

xxxx-xxxx-1

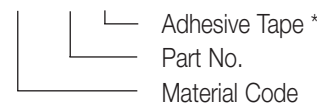

* If adhesive tape is required, please check possibility with customer service. For adhesive tape add „-1“ to the end of the order code.

All dimensions shown are in inches (millimeters) unless otherwise specified.



Fabricated All Mesh Gaskets

Laird Technologies can supply fabricated gaskets, specified from the products highlighted in this section, to meet a vast range of custom assembly requirements.

Shown below are guidelines for three standard construction configurations.

Figure 1. Single Fin Rectangular Construction

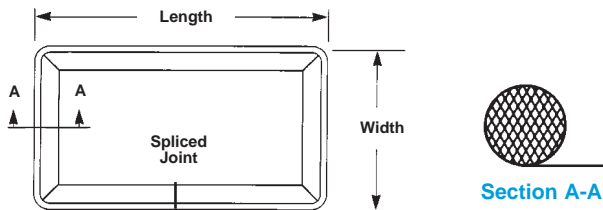

Tolerance

Size Range	Tolerance
2.0 to 6.0 (50.8 to 152.4)	± 0.030 (0,8)
6.0 to 12.0 (152.4 to 304.8)	± 0.046 (1,2)
12.0 to 18.0 (304.8 to 457.2)	± 0.062 (1,6)
18.0 to 24.0 (457.2 to 609.6)	± 0.093 (2,4)

Figure 2. O-Ring Construction

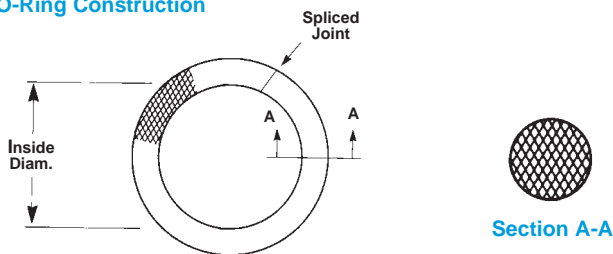

Tolerance

Size Range	Tolerance
2.0 to 4.0 (50.8 to 101.6)	± 0.020 (0,5)
4.0 to 8.0 (101.6 to 203.2)	± 0.030 (0,8)
8.0 to 12.0 (203.2 to 304.8)	± 0.046 (1,2)
12.0 to 18.0 (304.8 to 457.2)	± 0.062 (1,6)

Figure 3. Cut-to-length Rectangular

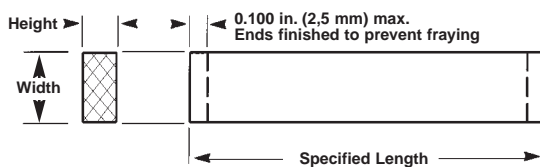

Tolerance

Size Range	Tolerance
1.0 to 4.0 (25.4 to 101.6)	± 0.030 (0,8)
4.0 to 8.0 (101.6 to 203.2)	± 0.060 (1,5)
8.0 to 12.0 (203.2 to 304.8)	± 0.093 (2,4)
12.0 to 18.0 (304.8 to 457.2)	± 0.125 (3,2)

LT_KA_2003_03_KC_E7_5M - ©2003 Laird Technologies

All dimensions shown are in inches (millimeters) unless otherwise specified.

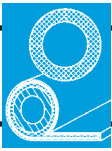

ElectroNit® Elastomer Core EMI Gasketing

ElectroNit® elastomer core EMI gaskets are elastomer cores usually with 2 layers of knitted wire mesh around if not indicated otherwise. These gaskets combine excellent shielding performance with high elasticity and provide an additional environmental sealing. As elastomer core we use mainly sponge neoprene or silicone. For hollow strips we use solid silicone as core to secure better elasticity whereas solid neoprene can only be used with a certain wall thickness due to stability reasons. Standard profiles are round, tubular or rectangular. Other profiles are possible on request. The wires used are mainly Monel®, a nickel-copper alloy with good ageing qualities and elasticity performance as well as high tensile strength. SCF offers the best H-field EMI shielding. Additional wire materials are stainless steel and aluminium. When selecting the wire, please consider the electrochemical compatibility to avoid galvanic corrosion. Optimum shielding is achieved with 2 layers of wire and 25 % compression with a closing force of 1,4 kp/cm². For very soft gasket strips, PU-foam is used. To maintain the elasticity of the foam, all PU-foam gasket strips only have 1 layer of knitted wire. Please refer to page 10 (ElectroNit® SuperSoft) ElectroNit® elastomer core EMI gaskets are not only available in continuous lengths but also as custom made gaskets. For mounting purposes some of the gaskets can optionally be provided with a non-conductive adhesive tape. Consult factory for feasibility.

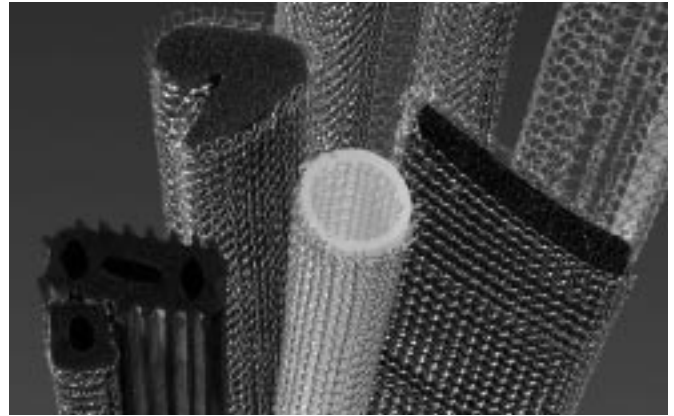

Suitable for enclosures and doors with low closing force as well as in sheet metal and moulded enclosures. Simple attachment by pressing into place or glueing the gasket into the groove (glue only spotwise). To facilitate assembly further, ElectroNit® elastomer core EMI gaskets are also available with fin or as double round with fin.

- Monel® = Alloy of copper (30 %) and nickel (67 %).
- SCF = Tinned copperclad steel. Steel (64 %), copper (34 % min), tin (2 %).

Material Code

Elastomer	Mesh			
	Monel®	Alu	Stainless steel	SCF
Sponge neoprene	8011-	8012-	8013-	8014-
Solid neoprene	8111-	8112-	8113-	8114-
Sponge Silicone	8211-	8212-	8213-	8214-
Solid silicone	8311-	8312-	8313-	8314-
PU-foam	8411-	8412-	8413-	8414-
Sponge EPDM	8511-	8512-	8513-	8514-
TPE	8611-	8612-	8613-	8614-
TPE UL94 HB	8661-	8662-	8663-	8664-*
TPE UL94 VO	8651-	8652-	8653-	8654-*

* UL approval no.: E 170327

Note:

- not all combinations Elastomer/Profile are possible or make sense
- Also available Monel® wire in Ø 0.002 inch (0,05 mm) and 0.004 inch (0,09 mm). SCF wire in 0.004 inch (0,09 mm).

Shielding Performance

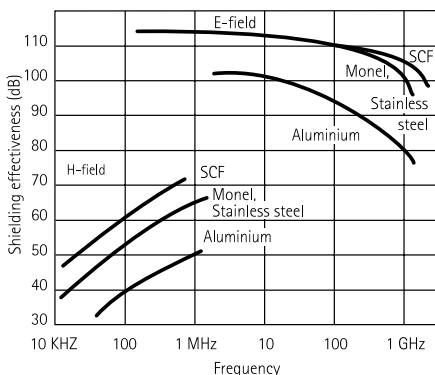

All dimensions shown are in inches (millimeters) unless otherwise specified.

Specifications

Mesh:	
Monel®:	Ø 0.004 inch (Ø 0,114 mm), DIN 17743/17750
Aluminium:	Ø 0.005 inch (Ø 0,127 mm), DIN 1725, Material-no. 3.3555, AMS-4182, Alloy 5056
Stainless steel:	Ø 0.004 inch (Ø 0,114 mm), DIN 17440
SCF:	Ø 0.004 inch (Ø 0,114 mm), ASTM-B-520

Mechanical Tolerances

Knitted mesh all dimensions		Knitted mesh all dimensions	
0.079 - 0.197 inch:	+ 0.016 - 0.0 inch	> 0.394 inch:	+ 0.059 - 0.020 inch
2 - 5 mm:	+ 0,4 - 0,0 mm	>10 mm:	+ 1,5 - 0,5 mm
> 0.197 - 0.394 inch:	+ 0.020 - 0.012 inch	0.590 inch:	+/- 0.079 inch
> 5 - 10 mm:	+ 0,5 - 0,3 mm	15 mm:	+/- 2 mm

Recommended Groove Size

For O-Strip Gaskets		
with 10 % compression:	depth: Ø x 0,9	width: Ø x 1,1
with 20 % compression:	depth: Ø x 0,8	width: Ø x 1,2

Elastomer	Standard	Shore	Cell-size	Density	Temperature	Colour
TPE	on request	on request	closed-cell	170 kg/m ³	-40° to +70°C	white
Sponge neoprene	MIL-R-6130 Type 2 Grade A	similar to shore 15 - 20	approx. 0,2 - 0,5 mm closed cell	180 - 240 kg/m ³	-31° to +100°C	black
Solid neoprene	MIL-R-6855 Class 2	60 - 70	on request	on request	-54° to +100°C	black
Sponge silicone	AMS-3195	similar to shore 15 - 20	on request	on request	-75° to +205°C	on request
Solid silicone	ZZ-R-765 Class 2	50 - 70	on request	on request	-62° to +260°C	on request
PU-foam	on request	on request	open cell	64 kg/m ³	-40° to +90°C	dark grey
Sponge EPDM	on request	on request	approx. 0,1 - 0,5 mm closed cell	130 - 170 kg/m ³	-40° to +100°C	black



ElectroNit® Elastomer Core EMI Gasketing

Dimensions

Advised dimensions are for the elastomer core including wire mesh (e.g. 8011-2004 is a neoprene core Ø 0.236 inch (Ø 6 mm) with 2 layers of Monel® and a total cross section of Ø 0.25 inch (Ø 6,35 mm)).

Compression Force

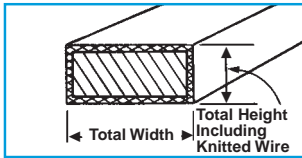
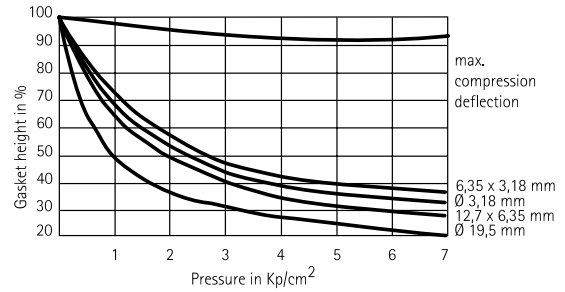

Rectangular with Sponge Elastomer

Rectangular with Sponge Elastomer

Part No.	Total Height	Total Width	Part No.	Total Height	Total Width
-2202	0.095 (2,4)	0.126 (3,2)	-2212	0.189 (4,8)	0.374 (9,5)
-2203	0.095 (2,4)	0.189 (4,8)	-2213	0.252 (6,4)	0.252 (6,4)
-2204	0.095 (2,4)	0.252 (6,4)	-2214	0.252 (6,4)	0.374 (9,5)
-2205	0.126 (3,2)	0.126 (3,2)	-2215	0.252 (6,4)	0.500 (12,7)
-2206	0.126 (3,2)	0.189 (4,8)	-2295	0.335 (8,5)	0.492 (12,5)
-2207	0.126 (3,2)	0.252 (6,4)	-2292	0.374 (9,5)	0.571 (14,5)
-2208	0.126 (3,2)	0.374 (9,5)	-2219	0.413 (10,5)	0.610 (15,5)
-2209	0.126 (3,2)	0.500 (12,7)	-2217	0.413 (10,5)	0.650 (16,5)
-2210	0.189 (4,8)	0.189 (4,8)	-2263	0.413 (10,5)	1.043 (26,5)
-2211	0.189 (4,8)	0.252 (6,4)			

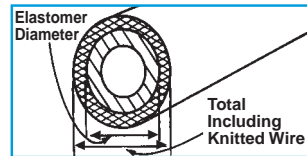

Round with Silicone Elastomer

Round with Silicone Elastomer

Part No.	A.D.	core i ø x wall thickness
-2101	0.094 (2,4)	0.04 x 0.01 (1,0 x 0,3)
-2102	0.126 (3,2)	0.06 x 0.02 (1,50 x 0,4)
-2103	0.189 (4,8)	0.08 x 0.04 (2,0 x 1,0)
-2104	0.252 (6,4)	0.16 x 0.04 (4,0 x 1,0)
-2105	0.311 (7,9)	0.16 x 0.07 (4,0 x 1,75)
-2106	0.374 (9,5)	0.18 x 0.09 (4,5 x 2,25)
-2115	0.394 (10,0)	0.26 x 0.06 (6,5 x 1,5)
-2108	0.500 (12,7)	0.28 x 0.10 (7,0 x 2,5)
-2109	0.571 (14,5)	0.43 x 0.06 (11,0 x 1,5)
-2110	0.622 (15,8)	0.31 x 0.14 (8,0 x 3,5)

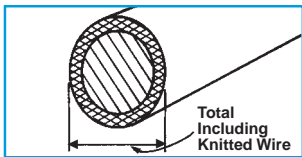

Round with Sponge Elastomer

Round with Sponge Elastomer

Part No.	Total Diameter Over Wire	Part No.	Total Diameter Over Wire
-2000	0.063 (1,6)	-2015	0.335 (8,5)
-2032	0.091 (2,3)	-2006	0.374 (9,5)
-2001	0.094 (2,4)	-2013	0.413 (10,5)
-2027	0.098 (2,5)	-2007	0.437 (11,1)
-2002	0.126 (3,2)	-2008	0.500 (12,7)
-2003	0.189 (4,8)	-2009	0.563 (14,3)
-2014	0.217 (5,5)	-2010	0.626 (15,9)
-2004	0.252 (6,4)	-2011	0.752 (19,1)
-2030	0.295 (7,5)	-2012	1.000 (25,4)
-2005	0.311 (7,9)		

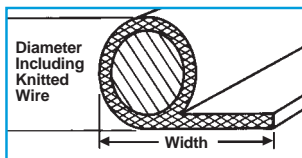

Single Fin with Sponge Elastomer

Single Fin with Sponge Elastomer

Part No.	Diameter	Width	Part No.	Diameter	Width	Part No.	Diameter	Width
-2301	0.063 (1,6)	0.531 (13,5)	-2317	0.189 (4,8)	0.626 (15,9)	-2329	3.740 (9,5)	0.752 (19,1)
-2302	0.063 (1,6)	0.626 (15,9)	-2318	0.189 (4,8)	0.752 (19,1)	-2330	3.740 (9,5)	0.874 (22,2)
-2303	0.063 (1,6)	0.752 (19,1)	-2319	0.189 (4,8)	0.874 (22,2)	-2331	3.740 (9,5)	1.000 (25,4)
-2305	0.095 (2,4)	0.531 (13,5)	-2320	0.252 (6,4)	0.531 (13,5)	-2332	0.437 (11,1)	0.752 (19,1)
-2306	0.095 (2,4)	0.752 (19,1)	-2321	0.252 (6,4)	0.626 (15,9)	-2333	0.437 (11,1)	0.874 (22,2)
-2309	0.126 (3,2)	0.531 (13,5)	-2322	0.252 (6,4)	0.752 (19,1)	-2334	0.437 (11,1)	1.000 (25,4)
-2310	0.126 (3,2)	0.563 (14,3)	-2323	0.252 (6,4)	0.874 (22,2)	-2335	0.500 (12,7)	0.752 (19,1)
-2311	0.126 (3,2)	0.626 (15,9)	-2324	0.252 (6,4)	1.000 (25,4)	-2336	0.500 (12,7)	0.874 (22,2)
-2312	0.126 (3,2)	0.752 (19,1)	-2325	0.311 (7,9)	0.626 (15,9)	-2337	0.500 (12,7)	1.000 (25,4)
-2313	0.158 (4,0)	0.531 (13,5)	-2326	0.311 (7,9)	0.752 (19,1)			
-2314	0.158 (4,0)	0.752 (19,1)	-2327	0.311 (7,9)	0.874 (22,2)			
-2316	0.189 (4,8)	0.531 (13,5)	-2328	3.740 (9,5)	0.626 (15,9)			

All dimensions shown are in inches (millimeters) unless otherwise specified.

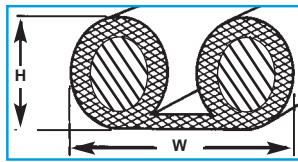

Double Fin with Sponge Elastomer

Double Fin with Sponge Elastomer

Part No.	Elastomer Diameter	Overall Width
-2401	0.063 (1,6)	0.531 (13,5)
-2402	0.063 (1,6)	0.626 (15,9)
-2403	0.063 (1,6)	0.752 (19,1)
-2404	0.063 (1,6)	0.874 (22,2)
-2405	0.095 (2,4)	0.531 (13,5)
-2420	0.098 (2,5)	1.000 (25,4)
-2406	0.126 (3,2)	0.531 (13,5)
-2407	0.126 (3,2)	0.626 (15,9)
-2408	0.126 (3,2)	0.752 (19,1)
-2409	0.126 (3,2)	0.874 (22,2)
-2410	0.126 (3,2)	1.000 (25,4)
-2411	0.189 (4,8)	0.626 (15,9)
-2412	0.189 (4,8)	0.752 (19,1)
-2413	0.189 (4,8)	0.874 (22,2)
-2414	0.189 (4,8)	1.000 (25,4)
-2415	0.252 (6,4)	0.752 (19,1)
-2416	0.252 (6,4)	0.874 (22,2)
-2417	0.252 (6,4)	1.000 (25,4)
-2418	0.374 (9,5)	1.000 (25,4)
-2419	0.374 (9,5)	1.252 (31,8)

Fabricated Elastomer Core Gaskets

The fabricated gaskets shown below can be provided to meet specific enclosure size and mounting criteria.

Figures 1 and 2 represent standard elastomer core construction. Please consult Laird Technologies engineering department at 1-800-843-4556 for elastomer core rectangular gaskets.

Figure 1. O-Ring Construction

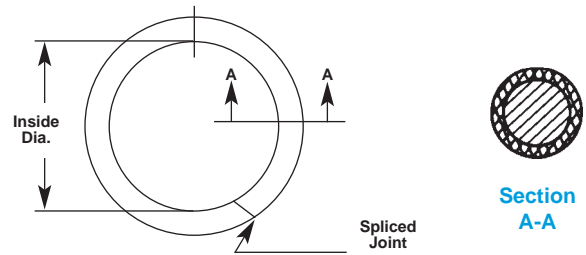

Tolerance

Diameter Size Range	Tolerance
2.0 to 4.0 (50,8 to 101,6)	± 0.020 (±0,5)
4.0 to 8.0 (101,6 to 203,2)	± 0.030 (±0,8)
8.0 to 12.0 (203,2 to 304,8)	± 0.046 (±1,2)
12.0 to 18.0 (304,8 to 457,2)	± 0.062 (±1,6)

Ordering Information

The ordering code consists of the material code, followed by the part no.:

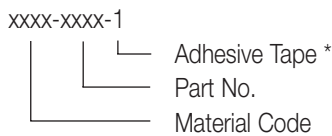

* If adhesive tape is required, please check possibility with customer service. For adhesive tape add „-1“ to the end of the order code.

Figure 2. Cut-to-length

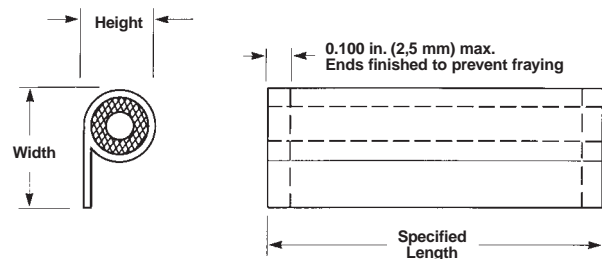

Tolerance on Length

Cut-to-Length Size Range	Tolerance
1.0 to 4.0 (25,4 to 101,6)	± 0.060 (±1,5)
4.0 to 8.0 (101,6 to 203,2)	± 0.060 (±1,5)
8.0 to 12.0 (203,2 to 304,8)	± 0.093 (±2,4)
12.0 to 18.0 (304,8 to 457,2)	± 0.125 (±3,2)
18.0 to 24.0 (457,2 to 609,6)	± 0.250 (±6,4)
24.0 to 30.0 (609,6 to 762,0)	+ 0.500/- 0.250 (+12,7/-6,4)
30.0 to 60.0 (762,0 to 1524,0)	+ 1.00/- 0.250 (+25,4/-6,4)
over 60.0 (1524,0)	+ 2.00/- 0.250 (+50,8/-6,4)

All dimensions shown are in inches (millimeters) unless otherwise specified.

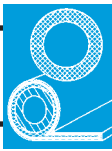

ElectroNit® Enviro-Seal™ EMI Gasketing

ElectroNit® EnviroSeal EMI gaskets consist of knitted wire mesh adhered to a sponge elastomer. Wire mesh knitted over elastomer is shown separately (pages 16-18). This combination provides both EMI/RFI shielding as well as environmental seal. Combi gaskets are available in continuous lengths and different profiles or as frame gasket made per customer specification. Combi gaskets can be supplied with an adhesive backing on the elastomer to facilitate assembly. Special combinations are possible at any time. Gaskets shown herein only indicate some of the possibilities. The recommended compression is 20 % of the total thickness. Combi gaskets can compensate major uneven spots and are therefore often preferred as lid gasket in enclosures. Despite the low compression required, the gasket provides a constant shielding performance and environmental seal and will not be affected adversely even in case of repeated opening/closing. The combi gasket can also be equipped with compression stops as additional protection.

- Monel® = Alloy of copper (30 %) and nickel (67 %).
- SCF = Tinned copperclad steel
Steel (64 %), copper (34 % min), tin (2 %).

Material Code

Elastomer	Mesh			
	Monel®	Alu	Stainless steel	SCF
Sponge neoprene	4011-	4012-	4013-	4014-
Sponge silicone	4211-	4212-	4213-	4214-
Sponge EPDM	4511-	4512-	4513-	4514-
TPE Sponge V0	4661-	4662-	4663-	4664-
TPE Sponge HB	4651-	4652-	4653-	4654-

Specifications

Mesh	
Monel®:	Ø 0.004 inch (Ø 0,114 mm) DIN 17743/17750, Material-no. 2.4360
Aluminium:	Ø 0.005 inch (Ø 0,127 mm) DIN 1725, Material-no. 3.3555, AMS-4182, Alloy 5056
Stainless steel:	Ø 0.004 inch (Ø 0,114 mm) DIN 17440, Material-no. 1.4301
SCF:	Ø 0.004 inch (Ø 0,114 mm) ASTM-B-520

Elastomer	Standard	Shore	Cell-size	Density	Temperature	Colour	Flammability
Sponge neoprene	MIL-R-6130 Type 2, Grade A	similar to shore 15 - 20	approx. 0,2 - 0,5 mm 0,008 - 0,020 inch closed cell	180 - 240 kg/m ³	-31° to +100°C	black	self-extinguishing
Sponge silicone	AMS-3195	similar to shore 15 - 20	on request	on request	-75° to +205°C	on request	on request
Sponge EPDM	on request	on request	approx. 0,1 - 0,5 mm 0,004 - 0,020 inch closed cell	130 - 170 kg/m ³	-40° to +100°C	black	burning
TPE	on request	on request	closed-cell	170 kg/m ³	-40° to +70°C	white	UL 94 V0, UL 94 HB

All dimensions shown are in inches (millimeters) unless otherwise specified.



Enviro-Seal™ gasketing is available in a wide range of sizes, with either silicone or neoprene environmental seal.

Mechanical Tolerances

Sponge elastomer:			
Height:		Width up to:	
0.079 - 0.118 inch:	± 0.016 inch	0.984 inch:	± 0.032 inch
2 - 3 mm:	± 0,4 mm	25 mm:	± 0,8 mm
> 0.118 - 0.472 inch:	± 0.032 inch		
> 3 - 12 mm:	± 0,8 mm		
Knitted mesh:			
0.079 - 0.197 inch:	+ 0.016 - 0.0 inch	> 0.394 inch:	+ 0.059 - 0.020 inch
2 - 5 mm:	+ 0,4 - 0,0 mm	>10 mm:	+ 1,5 - 0,5 mm
> 0.197 - 0.394 inch:	+ 0.020 - 0.012 inch		
> 5 - 10 mm:	+ 0,5 - 0,3 mm		

Shielding Effectiveness

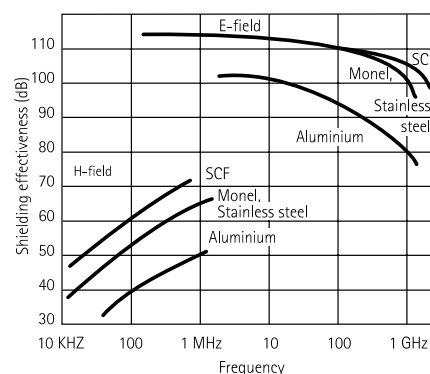

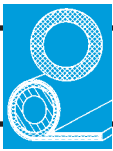

Examples Of Special Compositions

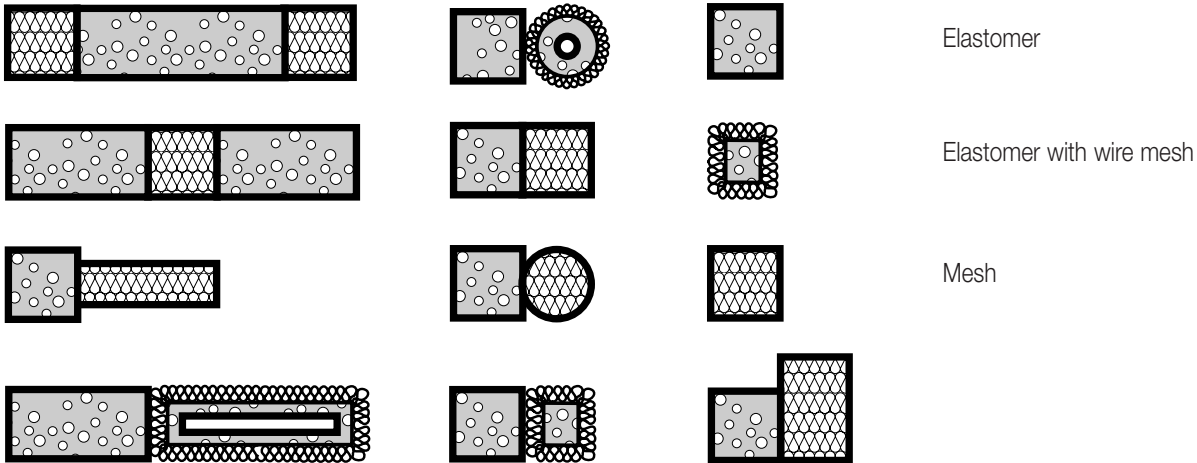

Gasket With Compression Stop

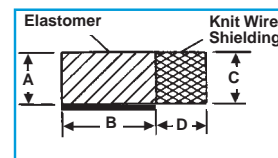
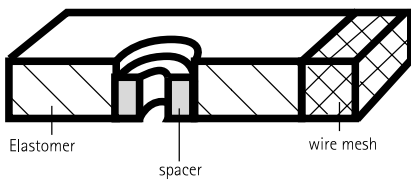

Application Design Data

Enviro-Seal™ gaskets are used in applications which require both moisture and dust sealing and EMI shielding. Presented in this section is a guide to several mounting methods, compression stop applications, and fabricated gaskets.

Mounting Methods

Figures 1a and 1b show two common methods used to mount Enviro-Seal™ gaskets.

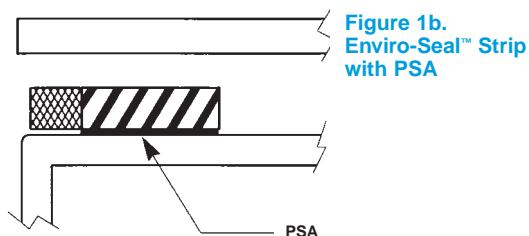
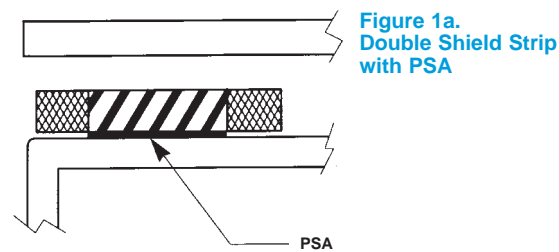

Enviro-Seal™ Strips with Pressure-Sensitive Adhesive (PSA)

Part No.	Dimensions			
	A	B	C	D
-1001	0.079 (2)	0.236 (6)	0.079 (2)	0.118 (3)
-1002*	0.079 (2)	0.354 (9)	0.079 (2)	0.118 (3)
-1003*	0.079 (2)	0.512 (13)	0.079 (2)	0.118 (3)
-1004*	0.079 (2)	0.630 (16)	0.079 (2)	0.118 (3)
-1005*	0.079 (2)	0.748 (19)	0.079 (2)	0.118 (3)
-1006	0.118 (3)	0.118 (3)	0.118 (3)	0.118 (3)
-1007	0.118 (3)	0.197 (5)	0.118 (3)	0.118 (3)
-1008	0.118 (3)	0.236 (6)	0.118 (3)	0.118 (3)
-1009	0.118 (3)	0.236 (6)	0.118 (3)	0.236 (6)
-1010	0.118 (3)	0.354 (9)	0.118 (3)	0.118 (3)
-1049	0.118 (3)	0.394 (10)	0.118 (3)	0.118 (3)
-1037	0.118 (3)	0.433 (11)	0.118 (3)	0.118 (3)
-1090	0.118 (3)	0.472 (12)	0.118 (3)	0.118 (3)
-1011	0.118 (3)	0.512 (13)	0.118 (3)	0.118 (3)
-1012	0.118 (3)	0.512 (13)	0.118 (3)	0.236 (6)
-1013	0.118 (3)	0.512 (13)	0.118 (3)	0.512 (13)
-1014*	0.118 (3)	0.630 (16)	0.118 (3)	0.118 (3)
-1015*	0.118 (3)	0.748 (19)	0.118 (3)	0.118 (3)
-1016	0.197 (5)	0.197 (5)	0.197 (5)	0.118 (3)
-1018	0.197 (5)	0.236 (6)	0.197 (5)	0.118 (3)
-1019	0.197 (5)	0.354 (9)	0.197 (5)	0.118 (3)
-1020	0.197 (5)	0.512 (13)	0.197 (5)	0.118 (3)
-1021*	0.197 (5)	0.748 (19)	0.197 (5)	0.236 (6)
-1022	0.236 (6)	0.236 (6)	0.236 (6)	0.118 (3)
-1023	0.236 (6)	0.512 (13)	0.236 (6)	0.118 (3)
-1025	0.354 (9)	0.236 (6)	0.354 (9)	0.118 (3)
-1026	0.354 (9)	0.512 (13)	0.354 (9)	0.236 (6)

* = not available in TPE

All dimensions shown are in inches (millimeters) unless otherwise specified.



ElectroNit® Flat Band

Flat band is a knitted metal gaze consisting of one layer of wire. It can be used to shield short cables by simply wrapping the band around the relevant cable. Flat band is also used to ensure proper contact between e.g. 2 metal plates that are rivetted together. To compensate uneven surfaces the flat band is simply placed between the 2 metal plates before they are rivetted together.

- Monel® = Alloy of copper (30 %) and nickel (67 %).
- SCF = Tinned copperclad steel. Steel (64 %), copper (34 % min), tin (2 %).

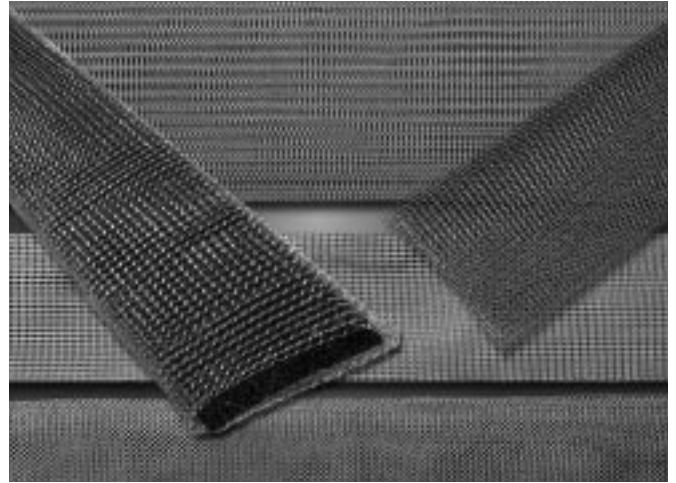

Flat Band

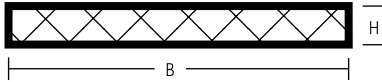

Material Code

Monel®	Alu	Stainless steel	SCF
7011-	7012-	7013-	7014-

Mechanical Tolerances

Height: ± 0.008 inch (0,2 mm)	Width: ± 0.197 inch (5,0 mm)
-------------------------------	------------------------------

ElectroNit® Flat Band

Part No.	H	B
-0500	0,020 (0,5)	0,394 (10)
-0515	0,020 (0,5)	0,551 (14)
-0501	0,020 (0,5)	0,709 (18)
-0502	0,020 (0,5)	0,984 (25)
-0507	0,020 (0,5)	1,260 (32)
-0503	0,020 (0,5)	1,575 (40)
-0511	0,020 (0,5)	2,165(55)

Other width on request

Ordering Information

The ordering code consists of the material code, followed by the part no. for dimensions:

xxxx-xxxx

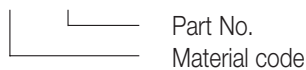

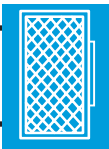

Laird Technologies UltraSoft® Knit EMI gasket material consists of a metalized nylon yarn knit over a flame retardant UL 94 HF-1 low density foam polyester core material. The close-knit stitch of the metalized nylon provides a highly effective EMI shield, as well as a smooth, soft surface that will not abrade plated plastic interfaces.

- UL 94 HF-1 approved core
- Excellent shielding effectiveness averaging 110 dB @ 10 KHz to 1 GHz
- Self-terminating ends
- 95% coverage of core material provides a smooth appearance and surface resistivity
- Low closure force of 8 lbs per foot (11.93 kg per meter) @ 30% deflection
- Available in silver plated nylon yarn to meet your galvanic compatibility needs
- Other finishes available upon request

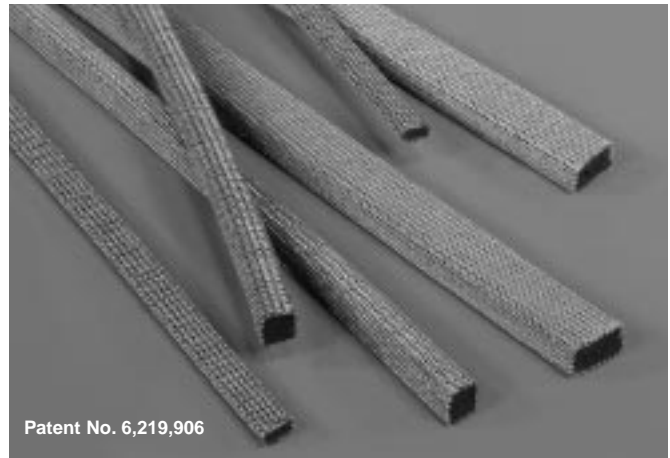

Patent No. 6,219,906

Product Specifications

Materials

- EMI Shield: Silver plated nylon (material code 62)
- Foam Core: Low density UL 94 HF-1 approved polyester
- Pressure Sensitive Adhesive: Acrylic

Performance Characteristics

- Surface Resistivity: Silver plate 0.051 ohm/square inch @ 20% deflection
- Compression Set: 10% @ 50% deflection
- Temperature Range:
Intermittent: -40°F to 225°F (-40°C to 107°C)

How to Order

1. Determine the size from Table 1 on page 23.
2. Most sizes are available in continuous length. Other length available upon request.
3. Custom gasket assemblies: All sizes are offered cut to a specific length, ready for installation as shown in Figure 2, or as a bonded assembly as shown in Figure 3. Submit dimensions and quantity requirements to our sales department for price and delivery.

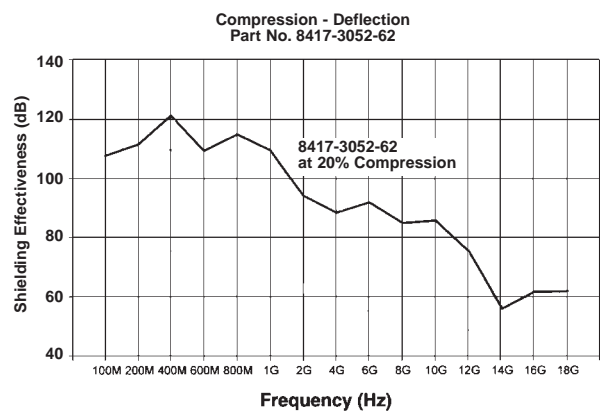
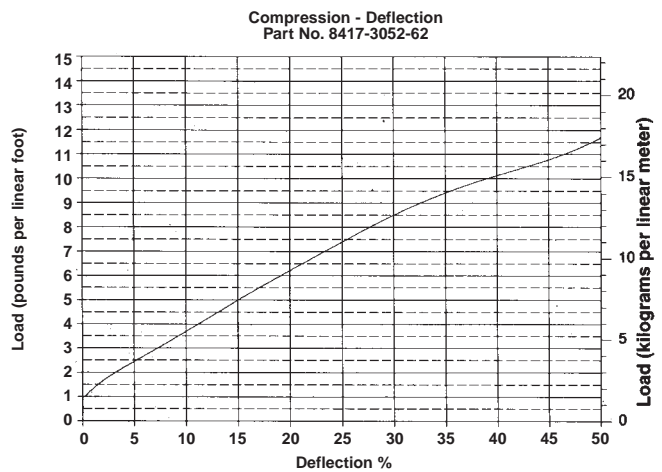

All dimensions shown are in inches (millimeters) unless otherwise specified.

Figure 1. UltraSoft® Knit Rectangle

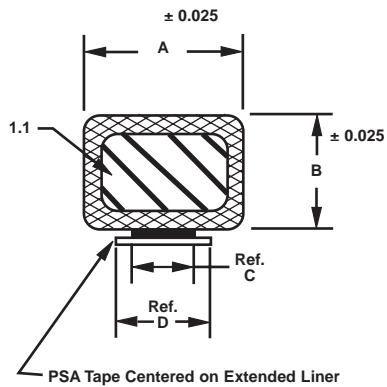

Table 1. UltraSoft® Knit Gaskets

Part No.	A	B	C	D
8417-3073-62	0.125 (3,2)	0.050 (1,3)	0.075 (1,9)	0.261 (6,6)
8417-3063-62	0.125 (3,2)	0.060 (1,5)	0.075 (1,9)	0.261 (6,6)
8417-3050-62	0.125 (3,2)	0.125 (3,2)	0.075 (1,9)	0.261 (6,6)
8417-3064-62	0.150 (3,8)	0.150 (3,8)	0.075 (1,9)	0.261 (6,6)
8417-3072-62	0.187 (4,7)	0.125 (3,2)	0.093 (2,4)	0.279 (7,1)
8417-3051-62	0.187 (4,7)	0.187 (4,7)	0.093 (2,4)	0.279 (7,1)
8417-3060-62	0.250 (6,4)	0.080 (2,0)	0.110 (2,8)	0.296 (7,5)
8417-3052-62	0.250 (6,4)	0.125 (3,2)	0.110 (2,8)	0.296 (7,5)
8417-3078-62	0.250 (6,4)	0.202 (5,1)	0.110 (2,8)	0.296 (7,5)
8417-3053-62	0.250 (6,4)	0.250 (6,4)	0.125 (3,2)	0.311 (7,9)
8417-3065-62	0.276 (7,0)	0.150 (3,8)	0.110 (2,8)	0.296 (7,5)
8417-3059-62	0.313 (8,0)	0.313 (8,0)	0.150 (3,8)	0.336 (8,5)
8417-3054-62	0.375 (9,5)	0.125 (3,2)	0.150 (3,8)	0.336 (8,5)
8417-3055-62	0.375 (9,5)	0.187 (4,7)	0.150 (3,8)	0.336 (8,5)
8417-3062-62	0.375 (9,5)	0.250 (6,4)	0.150 (3,8)	0.336 (8,5)
8417-3068-62	0.375 (9,5)	0.375 (9,5)	0.150 (3,8)	0.336 (8,5)
8417-3056-62	0.500 (12,7)	0.125 (3,2)	0.200 (5,1)	0.386 (9,8)
8417-3057-62	0.500 (12,7)	0.250 (6,4)	0.200 (5,1)	0.386 (9,8)
8417-3067-62	0.500 (12,7)	0.500 (12,7)	0.200 (5,1)	0.386 (9,8)
8417-3066-62	0.827 (21,0)	0.150 (3,8)	0.400 (10,2)	0.586 (14,9)
8417-3058-62	1.000 (25,4)	1.000 (25,4)	0.400 (10,2)	0.586 (14,9)

Figure 2. Cut-to-Length



Figure 3. Bonded Assembly

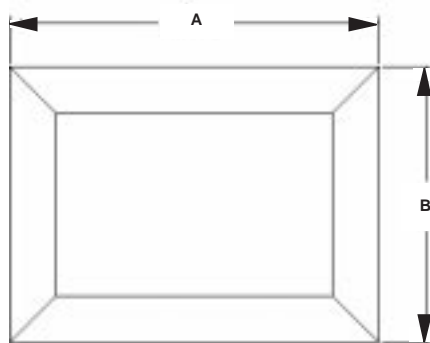

Note: A and B specified by customer.

All dimensions shown are in inches (millimeters) unless otherwise specified.



ElectroNit® Super Soft

Laird Technologies ElectroNit® Super Soft gasket material consist of one layer of knitted wire mesh over a flame retardant UL 94 HF-1 low density foam polyester core material. Two wires in three different diameters are available. Please refer to table Material Code on this page.

Rectangular Standard Profile

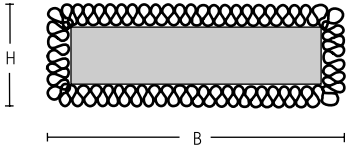

PU-foam with 1 layer only

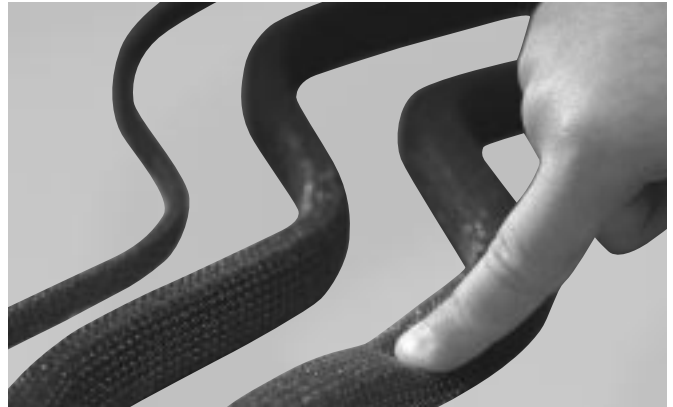

ElectroNit® Super Soft

Part No.	H	B
-2207	0.126 (3,2)	0.252 (6,4)
-2208	0.126 (3,2)	0.374 (9,5)
-2209	0.126 (3,2)	0.500 (12,7)
-2210	0.189 (4,8)	0.189 (4,8)
-2211	0.189 (4,8)	0.252 (6,4)
-2212	0.189 (4,8)	0.374 (9,5)
-2213	0.252 (6,4)	0.252 (6,4)
-2214	0.252 (6,4)	0.374 (9,5)
-2215	0.252 (6,4)	0.500 (12,7)

other dimensions on request

Material Code

Elastomer	Mesh			
	Monel®	Alu	Stainless steel	SCF
PU-Foam 0.004 inch wire (0,09 mm wire)	8437-	-	-	8438-
PU-Foam 0.002 inch wire (0,05 mm wire)	8439-	-	-	-

Ordering Information

The ordering code consists of the material code, followed by the part no. for dimensions: xxx-xxxx-1

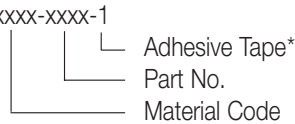

* If adhesive tape is required, please check possibility with customer service. For adhesive tape add „-1“ to the end of the order code.

All dimensions shown are in inches (millimeters) unless otherwise specified.



For applications requiring a resilient grounding medium with vibration dampening capabilities, Laird Technologies manufactures a knitted wire washer. Designed for use in compression or rotary applications, these washers can be made in a variety of sizes and shapes.

The interlocking loop structure of the fine wire mesh in the compressed washer shape acts as a spring. The force of that spring is controlled by varying the washer material density.

The fine wire alloy materials can be varied to meet the demands of the most hostile environment – e.g., salt fog, harsh chemicals, extremes of heat or cold.

- Effective grounding combined with vibration dampening, for applications such as PC board mounting
- Spring action, provided by the wire knit mesh's interlocking loop structure. We will vary the material density to provide the spring force you specify.
- Wide choice of materials. Choose from the metal or alloy that best suits your needs: beryllium copper, Monel®, aluminum, tin plated steel or stainless steel.
- Other alloys available upon request.



Three variables – size, density, and the metal or alloy of the mesh – can be controlled to give you the optimum configuration of properties.

Applications

ElectroGround™ washers can be used in compression or rotary applications. See Figures 1 through 4 below.

Figure 1.
With Washer and Jam Nut

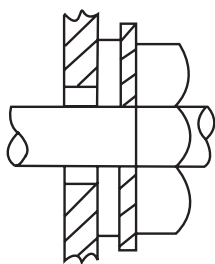

Figure 2.
With Shaft Shoulder

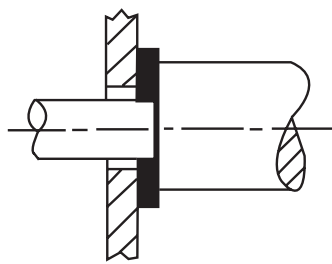

Figure 3.
With Positive Stop Cup Washer

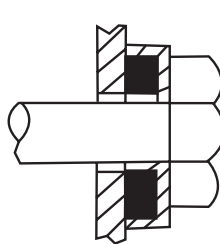
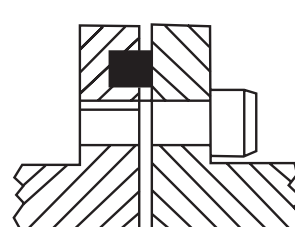
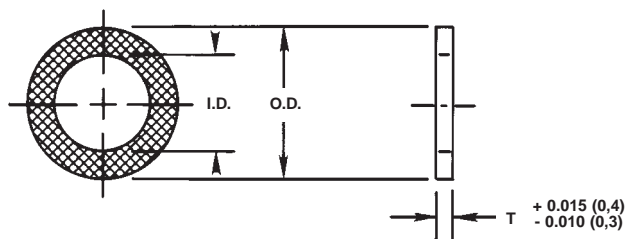

Figure 4.
Mounted in Flange Groove



**Figure 5. ElectroGround™ Washer Dimensions**

ElectroGround™ Washer Sizes, Materials and Tolerances

Table 1. Dimensions

Part No.	O.D.	I.D.	Free Height Maximum "T"
8904-0178-XX	0.200 (5,1)	0.125 (3,2)	0.032 (0,8)
8905-0178-XX	0.200 (5,1)	0.125 (3,2)	0.062 (1,6)
8906-0178-XX	0.200 (5,1)	0.125 (3,2)	0.093 (2,4)
8907-0178-XX	0.200 (5,1)	0.125 (3,2)	0.125 (3,2)
8908-0178-XX	0.200 (5,1)	0.125 (3,2)	0.156 (4,0)
8909-0178-XX	0.200 (5,1)	0.125 (3,2)	0.187 (4,7)
8910-0178-XX	0.200 (5,1)	0.125 (3,2)	0.250 (6,4)
8904-0107-XX	0.223 (5,7)	0.052 (1,3)	0.032 (0,8)
8902-0107-XX	0.223 (5,7)	0.052 (1,3)	0.062 (1,6)
8905-0107-XX	0.223 (5,7)	0.052 (1,3)	0.093 (2,4)
8901-0107-XX	0.223 (5,7)	0.052 (1,3)	0.125 (3,2)
8906-0107-XX	0.223 (5,7)	0.052 (1,3)	0.156 (4,0)
8907-0107-XX	0.223 (5,7)	0.052 (1,3)	0.187 (4,7)
8908-0107-XX	0.223 (5,7)	0.052 (1,3)	0.250 (6,4)
8902-0109-XX	0.225 (5,7)	0.120 (3,0)	0.032 (0,8)
8904-0109-XX	0.225 (5,7)	0.120 (3,0)	0.062 (1,6)
8905-0109-XX	0.225 (5,7)	0.120 (3,0)	0.093 (2,4)
8906-0109-XX	0.225 (5,7)	0.120 (3,0)	0.125 (3,2)
8907-0109-XX	0.225 (5,7)	0.120 (3,0)	0.156 (4,0)
8903-0109-XX	0.225 (5,7)	0.120 (3,0)	0.187 (4,7)
8908-0109-XX	0.225 (5,7)	0.120 (3,0)	0.250 (6,4)
8902-0118-XX	0.255 (6,5)	0.150 (3,8)	0.032 (0,8)
8906-0118-XX	0.255 (6,5)	0.150 (3,8)	0.062 (1,6)
8907-0118-XX	0.255 (6,5)	0.150 (3,8)	0.093 (2,4)
8904-0118-XX	0.255 (6,5)	0.150 (3,8)	0.125 (3,2)
8908-0118-XX	0.255 (6,5)	0.150 (3,8)	0.156 (4,0)
8901-0118-XX	0.255 (6,5)	0.150 (3,8)	0.187 (4,7)
8909-0118-XX	0.255 (6,5)	0.150 (3,8)	0.250 (6,4)
8902-0116-XX	0.375 (9,5)	0.240 (6,1)	0.032 (0,8)
8903-0116-XX	0.375 (9,5)	0.240 (6,1)	0.062 (1,6)
8901-0116-XX	0.375 (9,5)	0.240 (6,1)	0.093 (2,4)
8904-0116-XX	0.375 (9,5)	0.240 (6,1)	0.125 (3,2)
8905-0116-XX	0.375 (9,5)	0.240 (6,1)	0.156 (4,0)
8906-0116-XX	0.375 (9,5)	0.240 (6,1)	0.187 (4,7)
8907-0116-XX	0.375 (9,5)	0.240 (6,1)	0.250 (6,4)
8901-0117-XX	0.375 (9,5)	0.187 (4,8)	0.032 (0,8)
8905-0117-XX	0.375 (9,5)	0.187 (4,8)	0.062 (1,6)
8903-0117-XX	0.375 (9,5)	0.187 (4,8)	0.093 (2,4)
8902-0117-XX	0.375 (9,5)	0.187 (4,8)	0.125 (3,2)
8911-0117-XX	0.375 (9,5)	0.187 (4,8)	0.156 (4,0)
8912-0117-XX	0.375 (9,5)	0.187 (4,8)	0.187 (4,7)
8904-0117-XX	0.375 (9,5)	0.187 (4,8)	0.250 (6,4)
8909-0102-XX	0.459 (11,7)	0.335 (8,5)	0.032 (0,8)
8901-0102-XX	0.459 (11,7)	0.335 (8,5)	0.062 (1,6)
8910-0102-XX	0.459 (11,7)	0.335 (8,5)	0.093 (2,4)

All dimensions shown are in inches (millimeters) unless otherwise specified.

Table 1. Dimensions (continued)

Part No.	O.D.	I.D.	Free Height Maximum "T"
8902-0102-XX	0.459 (11,7)	0.335 (8,5)	0.125 (3,3)
8911-0102-XX	0.459 (11,7)	0.335 (8,5)	0.156 (4,0)
8912-0102-XX	0.459 (11,7)	0.335 (8,5)	0.187 (4,7)
8905-0102-XX	0.459 (11,7)	0.335 (8,5)	0.250 (6,4)
8902-0110-XX	0.500 (12,7)	0.172 (4,4)	0.032 (0,8)
8903-0110-XX	0.500 (12,7)	0.172 (4,4)	0.062 (1,6)
8904-0110-XX	0.500 (12,7)	0.172 (4,4)	0.093 (2,4)
8901-0110-XX	0.500 (12,7)	0.172 (4,4)	0.125 (3,2)
8905-0110-XX	0.500 (12,7)	0.172 (4,4)	0.156 (4,0)
8906-0110-XX	0.500 (12,7)	0.172 (4,4)	0.187 (4,7)
8907-0110-XX	0.500 (12,7)	0.172 (4,4)	0.250 (6,4)
8907-0101-XX	0.500 (12,7)	0.212 (5,4)	0.032 (0,8)
8904-0101-XX	0.500 (12,7)	0.212 (5,4)	0.062 (1,6)
8901-0101-XX	0.500 (12,7)	0.212 (5,4)	0.093 (2,4)
8906-0101-XX	0.500 (12,7)	0.212 (5,4)	0.125 (3,2)
8908-0101-XX	0.500 (12,7)	0.212 (5,4)	0.156 (4,0)
8909-0101-XX	0.500 (12,7)	0.212 (5,4)	0.187 (4,7)
8902-0101-XX	0.500 (12,7)	0.212 (5,4)	0.250 (6,4)
8908-0122-XX	0.500 (12,7)	0.240 (6,1)	0.032 (0,8)
8909-0122-XX	0.500 (12,7)	0.240 (6,1)	0.062 (1,6)
8910-0122-XX	0.500 (12,7)	0.240 (6,1)	0.093 (2,4)
8903-0122-XX	0.500 (12,7)	0.240 (6,1)	0.125 (3,2)
8911-0122-XX	0.500 (12,7)	0.240 (6,1)	0.156 (4,0)
8912-0122-XX	0.500 (12,7)	0.240 (6,1)	0.187 (4,7)
8902-0122-XX	0.500 (12,7)	0.240 (6,1)	0.250 (6,4)
8904-0105-XX	0.500 (12,7)	0.312 (7,9)	0.032 (0,8)
8918-0105-XX	0.500 (12,7)	0.312 (7,9)	0.062 (1,6)
8919-0105-XX	0.500 (12,7)	0.312 (7,9)	0.093 (2,4)
8909-0105-XX	0.500 (12,7)	0.312 (7,9)	0.125 (3,2)
8903-0105-XX	0.500 (12,7)	0.312 (7,9)	0.156 (4,0)
8920-0105-XX	0.500 (12,7)	0.312 (7,9)	0.187 (4,7)
8910-0105-XX	0.500 (12,7)	0.312 (7,9)	0.250 (6,4)
8902-0108-XX	0.500 (12,7)	0.375 (9,5)	0.032 (0,8)
8907-0108-XX	0.500 (12,7)	0.375 (9,5)	0.062 (1,6)
8908-0108-XX	0.500 (12,7)	0.375 (9,5)	0.093 (2,4)
8909-0108-XX	0.500 (12,7)	0.375 (9,5)	0.125 (3,2)
8910-0108-XX	0.500 (12,7)	0.375 (9,5)	0.156 (4,0)
8906-0108-XX	0.500 (12,7)	0.375 (9,5)	0.187 (4,7)
8911-0108-XX	0.500 (12,7)	0.375 (9,5)	0.250 (6,4)
8908-0125-XX	0.525 (13,3)	0.355 (9,0)	0.032 (0,8)
8909-0125-XX	0.525 (13,3)	0.355 (9,0)	0.062 (1,6)
8904-0125-XX	0.525 (13,3)	0.355 (9,0)	0.093 (2,4)
8910-0125-XX	0.525 (13,3)	0.355 (9,0)	0.125 (3,2)
8911-0125-XX	0.525 (13,3)	0.355 (9,0)	0.156 (4,0)
8912-0125-XX	0.525 (13,3)	0.355 (9,0)	0.187 (4,8)
8903-0125-XX	0.525 (13,3)	0.355 (9,0)	0.250 (6,4)
8902-0129-XX	0.625 (15,9)	0.250 (6,4)	0.032 (0,8)
8903-0129-XX	0.625 (15,9)	0.250 (6,4)	0.062 (1,6)
8904-0129-XX	0.625 (15,9)	0.250 (6,4)	0.093 (2,4)
8905-0129-XX	0.625 (15,9)	0.250 (6,4)	0.125 (3,2)
8906-0129-XX	0.625 (15,9)	0.250 (6,4)	0.156 (4,0)
8907-0129-XX	0.625 (15,9)	0.250 (6,4)	0.187 (4,7)
8908-0129-XX	0.625 (15,9)	0.250 (6,4)	0.250 (6,4)
8911-0130-XX	0.625 (15,9)	0.370 (9,4)	0.032 (0,8)
8914-0130-XX	0.625 (15,9)	0.370 (9,4)	0.062 (1,6)
8913-0130-XX	0.625 (15,9)	0.370 (9,4)	0.093 (2,4)
8915-0130-XX	0.625 (15,9)	0.370 (9,4)	0.125 (3,2)
8901-0130-XX	0.625 (15,9)	0.370 (9,4)	0.156 (4,0)
8917-0130-XX	0.625 (15,9)	0.370 (9,4)	0.187 (4,7)
8904-0130-XX	0.625 (15,9)	0.370 (9,4)	0.250 (6,4)
8903-0180-XX	0.625 (15,9)	0.460 (11,7)	0.032 (0,8)
8904-0180-XX	0.625 (15,9)	0.460 (11,7)	0.062 (1,6)
8905-0180-XX	0.625 (15,9)	0.460 (11,7)	0.093 (2,4)
8906-0180-XX	0.625 (15,9)	0.460 (11,7)	0.125 (3,2)
8907-0180-XX	0.625 (15,9)	0.460 (11,7)	0.156 (4,0)
8901-0180-XX	0.625 (15,9)	0.460 (11,7)	0.187 (4,7)
8908-0180-XX	0.625 (15,9)	0.460 (11,7)	0.250 (6,4)
8903-0135-XX	0.625 (15,9)	0.490 (12,4)	0.032 (0,8)
8918-0135-XX	0.625 (15,9)	0.490 (12,4)	0.062 (1,6)

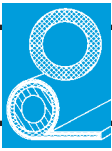

Channel Clip-On Gaskets

Laird Technologies offers the channel clip-on gasket, providing users with the ease of a clip-on mounting channel adaptable to a variety of gasket materials.

- Available in customized kits of various gasketing materials with finished terminations
- Also available in a continuous length of gasketing material, resulting in gap-free corners, thereby providing an additional 20 dB in shielding effectiveness
- Unique clip-on channel base provides easy snap-in installation of EMI gasketing materials
- Lances in channel mount bite into grounding surface providing positive retention and preserving conductivity
- Channel provides gasket protection, positive stop, and additional RF barrier
- Channel can be painted to match cabinet color

How to Specify

1. Determine which base part number best suits your application:
 - a. Four-piece EMI gasket 8644-0100-XX
 - b. One-piece EMI gasket 8645-0100-XX
2. Determine lengths required to fit door mounting surface to nearest hundredth of an inch (L & W dimensional Figure 1). Convert millimeters to inches for ordering. Each door will require two pieces each for L and W dimension.
3. Insert lengths in place of 0100 of base part number.
4. Example:
 - a. Length required: 19.25 in. (Convert millimeters to inches for ordering.)
 - b. Part number 8644-1925-XX
5. Determine material code (41 or 65).*
6. Insert material code in place of XX.
7. The four-piece construction is supplied with EMI gasket installed in channel with ends sealed to prevent fray.
8. The one-piece EMI gasket will be cut to a length 6.00 in. longer than door opening periphery and packaged separately from channel for shipping. (Instructions for joint termination will be included in your order.)

Material

1. EMI Gasket:
 - ***Code 41** - UltraFlex® "D" shaped tin plated beryllium copper wire hollow core
 - ***Code 65** - ElectroNit® tin copper plated steel wire over silicone hollow "D" elastomer core
2. Channel Clip-On: Stainless steel 304

Figure 1. Inside View of Door

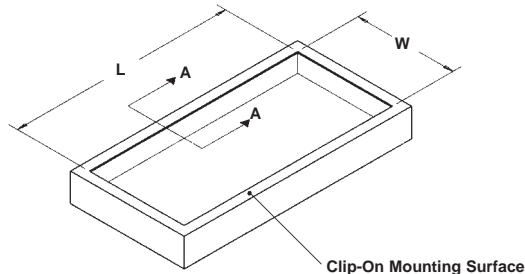

All dimensions shown are in inches (millimeters) unless otherwise specified.

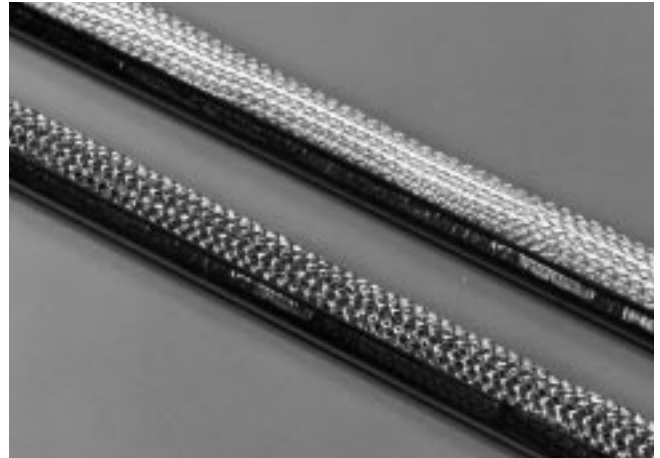

Clip-On Channel Mount Comparison Testing Using MIL-285 Radiated Method

Shielding Effectiveness

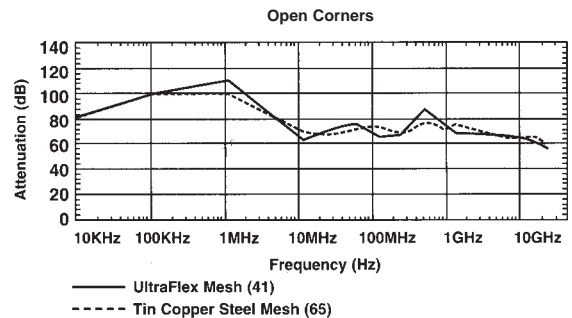
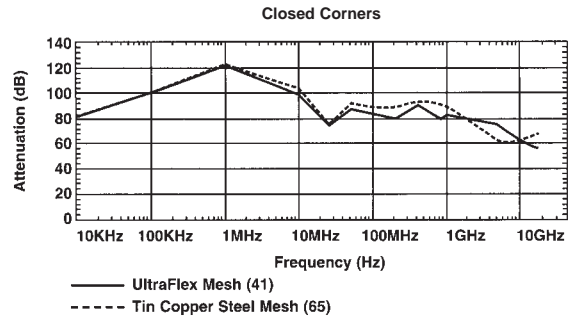

Channel Mount

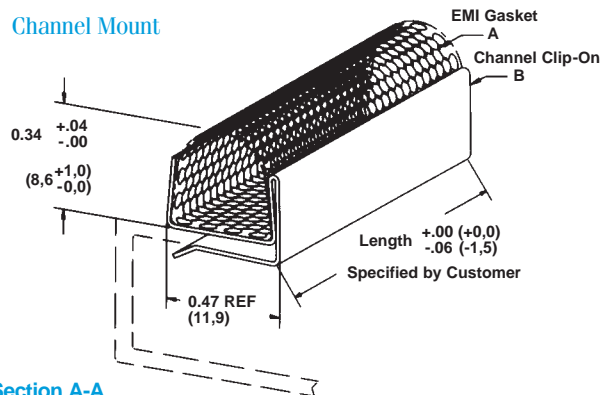

Section A-A

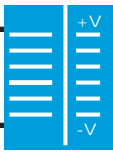

Galvanic Corrosion of Metals

The galvanic series is a common means of ranking the relative activity of metallic couples. The galvanic series does not provide a measure of the corrosion current which will flow in a dissimilar metal couple, but it does indicate which couples are likely to incur significant corrosion damage. In galvanic couples consisting of two very incompatible metals, it is possible to reduce the corrosion rate through good design practice. In this situation, it is best to maximize the ratio of anode to cathode surface areas. For a particular current density, the corrosion rate on the more anodic metal will be lower the larger this ratio, because the corrosion reaction is spread over a larger surface area. In addition, if corrosion products build up on the cathode, they will build at a faster rate the smaller the surface area of the cathode relative to the anode. In this situation, the deposits could create a barrier that slows down corrosion.

The above technique is used in reverse to enhance the performance of electrical contacts. It is desirable that electrical contacts remain clean to provide a low resistance connection. When corrosion occurs, metal is removed from the more anodic metal. This process cleans the more anodic metal. By making the electrical contact out of one metal, and surrounding it by a larger surface area of a more cathodic metal, the contact will be cleaned by the corrosion reaction. The contact may corrode away eventually, but it will function more reliably during its shortened life.

The probability that two dissimilar metals will corrode when coupled together can be predicted from their difference in the electrochemical potentials. This information is tabulated in the Metals Galvanic Compatibility Chart on page 34. The common metals and their anodic index are listed along the left side of the chart. The metals are grouped in 0.05 volt increments, with some of the groups containing no common metals. Group Number One (left hand column) contains the most cathodic metals and has an anodic index of zero. The anodic index increases as metals become more anodic. The arrow (on the far right

hand side of the chart) points in the direction of increasingly anodic metals. On the right side of the chart, typical finishes available on metallic parts manufactured by Laird Technologies are listed along the top. The colored bars indicate the galvanic compatibility of these common finishes to the metals listed on the left. The color code is based on both the electrochemical differences between the metals and the finishes, and the corrosiveness of the environment. The chart shows that the force that drives the corrosion reactions is directly related to the electrochemical difference between any two metals. By reducing this difference, the corrosion rate is decreased.

Basic Corrosion Prevention

Whenever possible, avoid the use of dissimilar metals. The following five steps may be taken to prevent, or at least minimize corrosion potential in the event that it is necessary to use dissimilar metals in intimate contact with one another:

1. Limit contact between metals with widely different electrochemical potentials. The Metals Galvanic Compatibility Chart, on page 34, indicates which metal pairs have large differences in electrochemical potential.
2. Insert a third metal between the two dissimilar metals which reduces the potential difference of the galvanic couple. For example, nickel or tin plated copper are suitable for use with aluminum and silver combinations.
3. Design the flange interface so that the surface area of the anodic metal is significantly larger than the cathodic metal. The electromotive force (EMF) difference remains the same. However, the current density is decreased, so the corrosive attack on the cathodic metal is reduced.
4. Eliminate moisture, salts and other electrolytes from entering the joint interface by improved flange design or, if not possible, use an environmental seal outboard of the conductive element in a dual EMI shield/ environmental seal.



Metals Galvanic Compatibility Chart

GROUP NUMBER	Common Metal Surfaces METALLURGICAL CATEGORY	ANODIC INDEX, V
1	Gold; Au-Pt alloys; wrought platinum; graphite carbon	0.00
2		0.05
3	Rhodium plating	0.10
4	Silver; high-silver alloys	0.15
5		0.20
6		0.25
7	Nickel; nickel-copper alloys; titanium, titanium alloys; Monel®	0.30
8	Beryllium copper; low brasses or bronzes; silver solder; copper; Ni-Cr alloys; austenitic corrosion-resistant steels; most chrome-moly steels; specialty high-temp stainless steels	0.35
9	Commercial yellow brasses and bronzes	0.40
10	High brasses and bronzes; naval brass; Muntz metal	0.45
11	18% Cr type corrosion resistant steels; common 300 series stainless steels	0.50
12		0.55
13	Chromium or tin plating; 12% Cr type corrosion resistant steels; most 400 series stainless steels, i.e., 410 and some cast stainless steels	0.60
14	Terneplate; tin-lead solder	0.65
15	Lead; high-lead alloys	0.70
16	Wrought 2000 series aluminum alloys	0.75
17		0.80
18	Wrought gray or malleable iron; plain carbon and low-alloy steels; armco iron; cold-rolled steel	0.85
19	Wrought aluminum alloys except 2000 series cast Al-Si alloys; 6000 series aluminum	0.90
20	Cast aluminum alloys other than Al-Si; cadmium plating	0.95
21		1.00
22		1.05
23		1.10
24		1.15
25	Hot-dip galvanized or electrogalvanized steel	1.20
26	Wrought zinc; zinc die casting alloys	1.25
27		1.30
28		1.35
29		1.40
30		1.45
31		1.50
32		1.55
33		1.60
34		1.65
35		1.70
36	Wrought and cast magnesium alloys	1.75
37		1.80
38	Beryllium	1.85

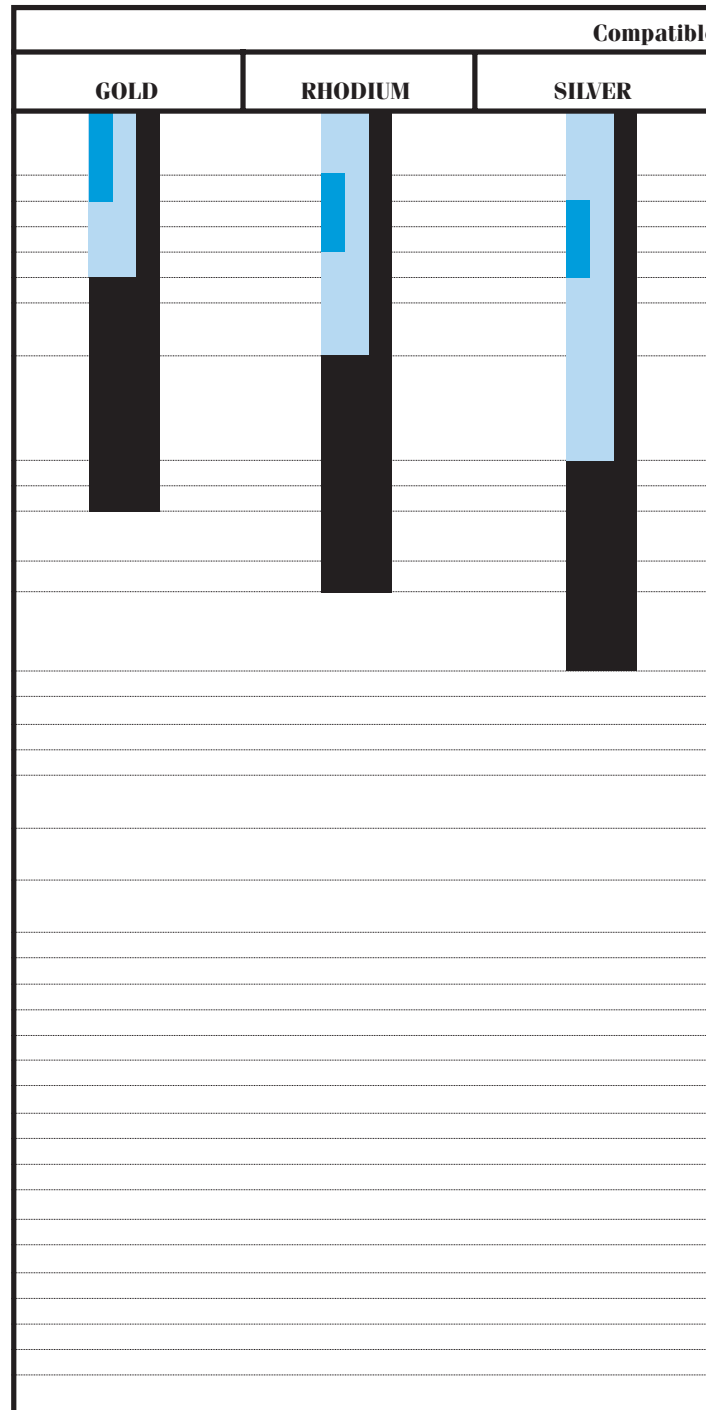

For harsh environments (presence of fair to good ionic conductors), all metals in contact with each other should be no more than one level of the chart apart to minimize corrosion. This is shown by the dark blue regions of the plating bar chart under specific platings. Outdoor applications, high humidity, and salt air fall into this category.

For normal environments (storage in warehouses or non-temperature/humidity-controlled environments, etc.), the difference between dissimilar metals should not exceed 0.25 volts (5 chart levels counting the origin). This is shown by the light blue regions of the chart under specific platings.

All dimensions shown are in inches (millimeters) unless otherwise specified.

e Surface Finishes for Laird Technologies Products

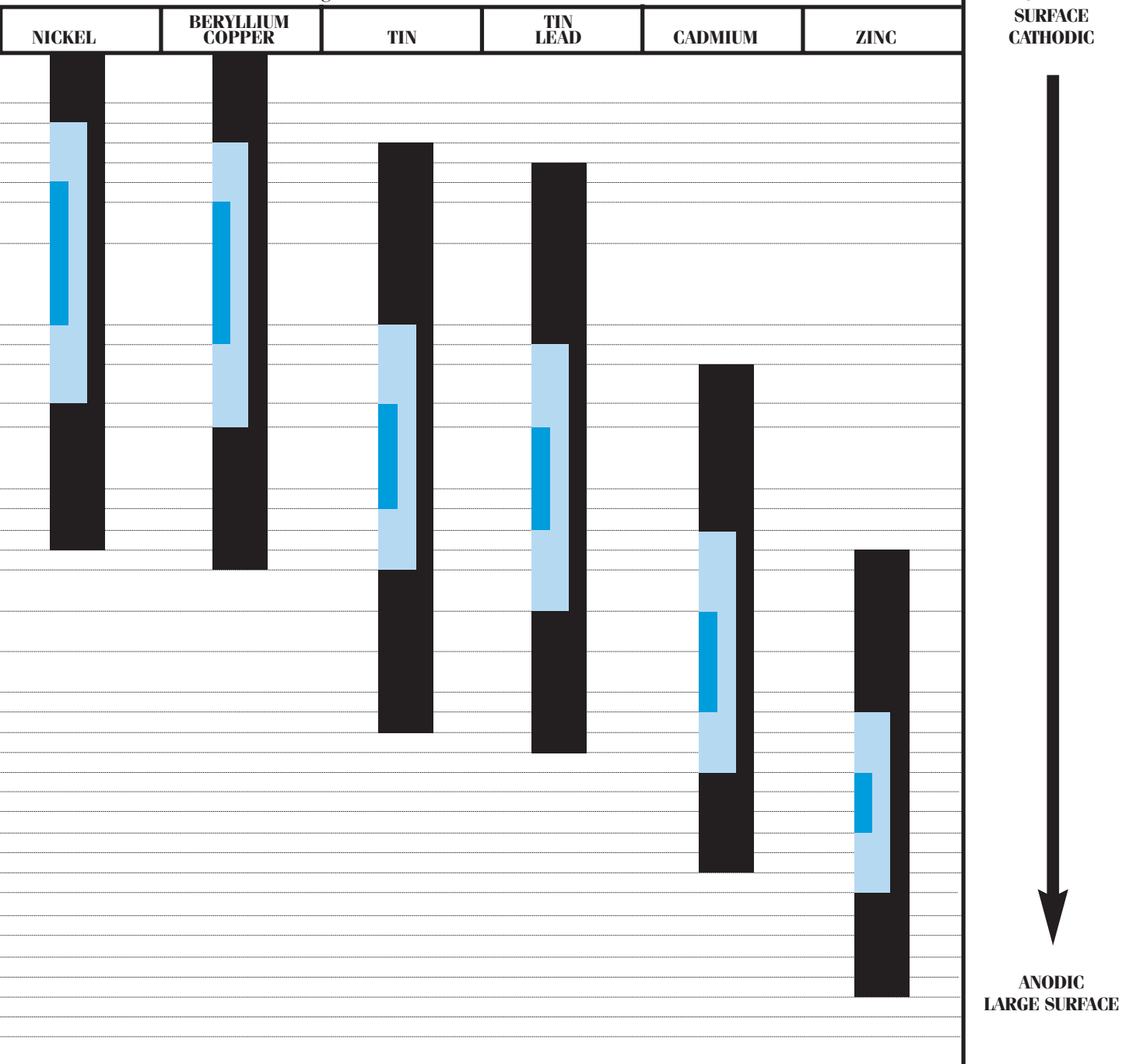

For office environments (temperature and humidity controlled), 0.5 volts can be tolerated (10 chart levels counting the origin). This is shown by the black regions under specific platings. Caution should be maintained when deciding that your application is temperature and humidity controlled. Many devices intended for use in office environments are stored in warehouses for extended periods of time before and in between use.

These are general guidelines which apply under most circumstances, but corrosion is a very complex subject whose details could not possibly fit in this space. If you are not sure which metals are compatible, please feel free to contact Laird Technologies and talk to our corrosion experts.

All dimensions shown are in inches (millimeters) unless otherwise specified.



Effective shielding solutions for a great variety of applications

European Locations

Germany

Laird Technologies GmbH
Äußere Oberastraße 22
83026 Rosenheim, Germany
Phone +49 (0) 80 31/24 60 0
Fax +49 (0) 80 31/24 60 50
europe@lairdtech.com



UK

Laird Technologies Ltd.
Warner Drive
Springwood Industrial Estate
Braintree
Essex CM7 2YW
Phone +44 (0) 13 76/34 26 26
Fax +44 (0) 13 76/34 64 42
europe@lairdtech.com



France

Laird Technologies SAS
13 -15 rue des Entrepreneurs
91560 Crosne, France
Phone +33 (0) 1 69/49 79 79
Fax +33 (0) 1 69/49 79 80
europe@lairdtech.com



Czech Republic

Laird Technologies s. r. o.
Průmyslová 497
46211 Liberec
Phone +420 4 88/57 51 11
Fax +420 4 88/57 53 03
europe@lairdtech.com



www.lairdtech.com

